

Rectangular Butterfly Gates

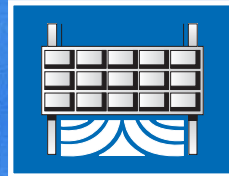

**Hydro
Gate**

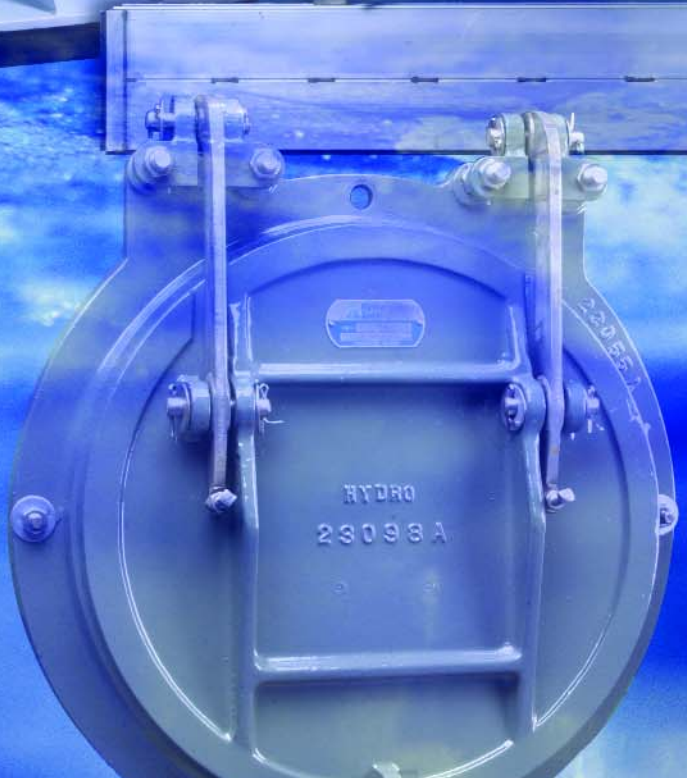

Pioneers in Gate Design

Hydro Gate 

3888 E. 45th Ave.
#120
Denver, CO 80216

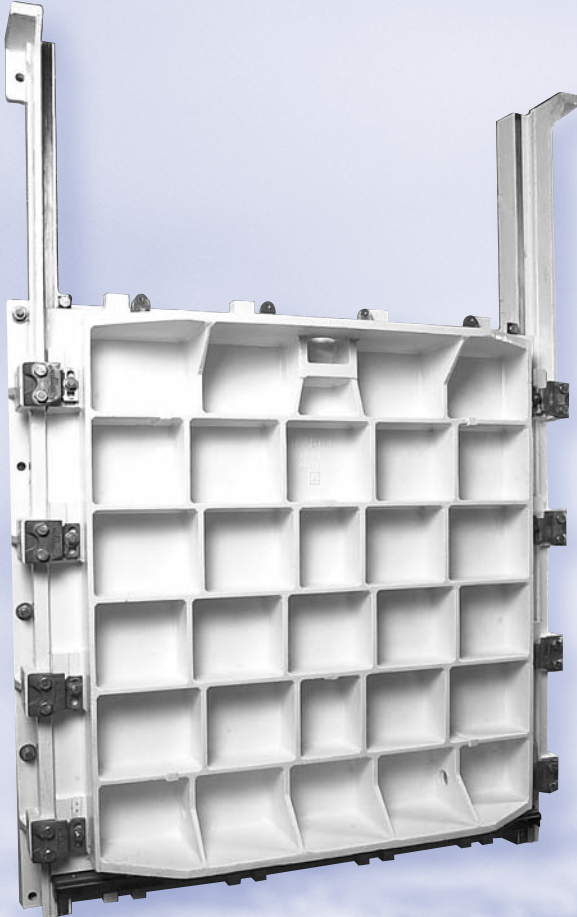

With more than 100 years of experience in gate design, Hydro Gate has built a long-standing reputation of providing superior quality water control gates for a variety of industries. Our manufacturing expertise revolves around making big, heavy-duty gates that are 100% custom-built to match specific applications.

Commitment to You... Our Customer

At Hydro Gate, customer satisfaction is our top priority. Bring your special requirements to our engineers who have years of experience in gate design. Our dedicated customer service staff is accustomed to custom requests, because that is what we do best. From your first contact through final delivery, our team of engineers and service experts are here to make sure you have the right gates to suit your needs.

Your Source for Water Control Gates

No matter what type of gates your project demands, chances are excellent Hydro Gate has the right gates for your specific application. Our product offering is vast and can suit applications for a wide variety of industries. Choose from cast iron slide or flap gates, fabricated slide or flap gates, rectangular butterfly gates, stop logs, wall thimbles, lifts and accessories.

Industries We Serve

Whether you need gates for flood control, wastewater treatment, environmental water treatment, irrigation, dam projects or hydroelectric plants, we can help. From standard configurations to custom designs, Hydro Gate offers a wide variety of water control gates as well as a full complement of actuators to meet your specific application.

Service Well Beyond Shipment

Our services extend beyond manufacturing. Hydro Gate's experienced field service technicians can help you with repair and refurbishment projects. If you have existing, yet serviceable gates, we can perform a retrofit that will extend their life and durability.

Focus on Quality

Hydro Gates expansive 90,000 square foot manufacturing facility utilizes precision equipment that allows us to merge time-tested gate design with cutting edge technology. We offer large scale manufacturing capabilities with the ability to produce cast iron gates up to 14' x 16' in size, and fabricated gates up to and over 20' in width or height.



Rectangular Butterfly Gate

Hydro Gate 

Table of Contents

Applications.....	2
Description	2
Material Specifications	2-3
Features.....	3
Special Requirements	3
Design Details.....	4-5
Jack Bolt Mounting System	6
Wall Thimble Mounting System	7
Water Flow Characteristics.....	8
Dimensional Data.....	9-10
Specifications	11
Actuation	12



Rectangular Butterfly Gate



Rectangular Butterfly Gate

Applications

- Water Filtration Plants
- Sewage Treatment Plants
- Flood Control
- Power Plants
- Industrial Applications

Description

Sizes:

- 3 ft. by 3 ft. up to 12 ft. by 12 ft.
- Consult factory for larger sizes

Body Styles:

- Three or four sided, in the following end configurations:
 - Weld End
 - Flanged
 - Jack Bolt

Pressure Ratings:

- Standard operating pressure differential is 10 psig.
- Designs available from vacuum to 25 psig differential

Seat:

- Rubber seat-in-body
- Mounted on four sides or three sides (open top)

Actuation Options:

- Hydro Gate manual actuator with handwheel or chainwheel
- Worm gear actuator
- Hydraulic or pneumatic cylinder
- Electric actuator

Accessories/Options:

- Position indicators
- Limit switches
- Pressure switches
- Extension bonnets
- Speed control devices
- Push button controls

Consult factory for accessory details.

Material Specifications

Body Material:

Carbon Steel - ASTM A36

Disc Edge:

Stainless Steel - ASTM A276 Type 304

Bearing Material:

Duralon - Teflon lined, Fiberglass backed

Disc Material:

Carbon Steel - ASTM A36

Shaft Material:

Stainless Steel - ASTM A276 Type 304

For other available materials, consult factory.

Materials

Typical Material Code	Type of Material						
	Body	Disc	Disc Edge	Shaft	Seat	Bearing	Packing
1101	Carbon Steel	Carbon Steel	304 S.S.	304 S.S.	Buna N	Duralon	Chevron V-Type

Features

Rubber seat-in-body

Thrust bearing located in the top trunnion

Uninterrupted seat configuration

90-degree turn to go from full open to fully closed

Simplified means of operation with reduced space requirements

Nonmetallic bearings

Sensitive flow control

No metal-to-metal contact on Seating surface

Jack bolt mounting

Benefits

- Reduces seat failure due to corrosive buildup. Seat can be adjusted or replaced from both sides of disc (as an option) in the field in most cases without removing the gate from the line.
- The two-way thrust bearing is fully accessible from the top of the gate if adjustment should ever be necessary.
- Bubble tight closure in both directions assured by means of a stainless steel disc edge closing onto a rubber seat.
- Easier to operate. Typically can be operated with one-tenth the number of turns required to achieve the same effect with a slide gate in the same service.
- Compact design requires less than one-half of the overhead operating clearance required for a slide gate.
- Prevents galvanic corrosion and provides lower coefficient of friction.
- Excellent for throttling or modulating service versus slide gate designs that do not adapt well to throttling service.
- Excellent wearing qualities versus the typical slide gate which depends on the disc sliding on the seat and guide.
- Ease of installation. Gate can be installed after channel is completed.

Special Requirements

Whatever the application, the Hydro Gate rectangular butterfly gate can be manufactured to meet your specific size, location and operating requirements. If manual actuation is required, we can supply a handwheel, chainwheel or a worm gear actuator. When automatic actuation is required, we can provide an electric actuator, or a pneumatic or hydraulic cylinder actuator, with or without manual override for open/close service, throttling or modulating service. Regardless of type, actuators may be mounted in a variety of positions for maximum convenience in installation and operation. All Hydro Gate actuators are designed for long life with minimal maintenance, backed by decades of experience and industry know-how.

Design Details

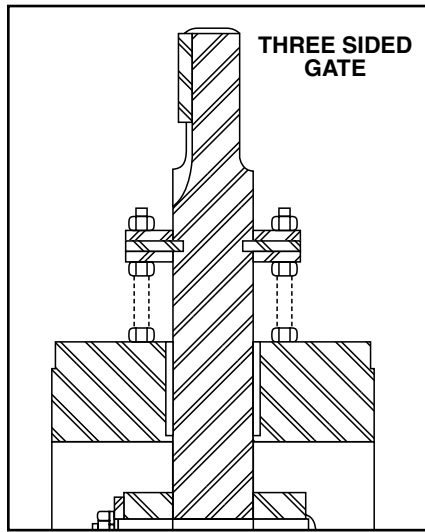

Tight seal on 3 sides

Four Sided Gate

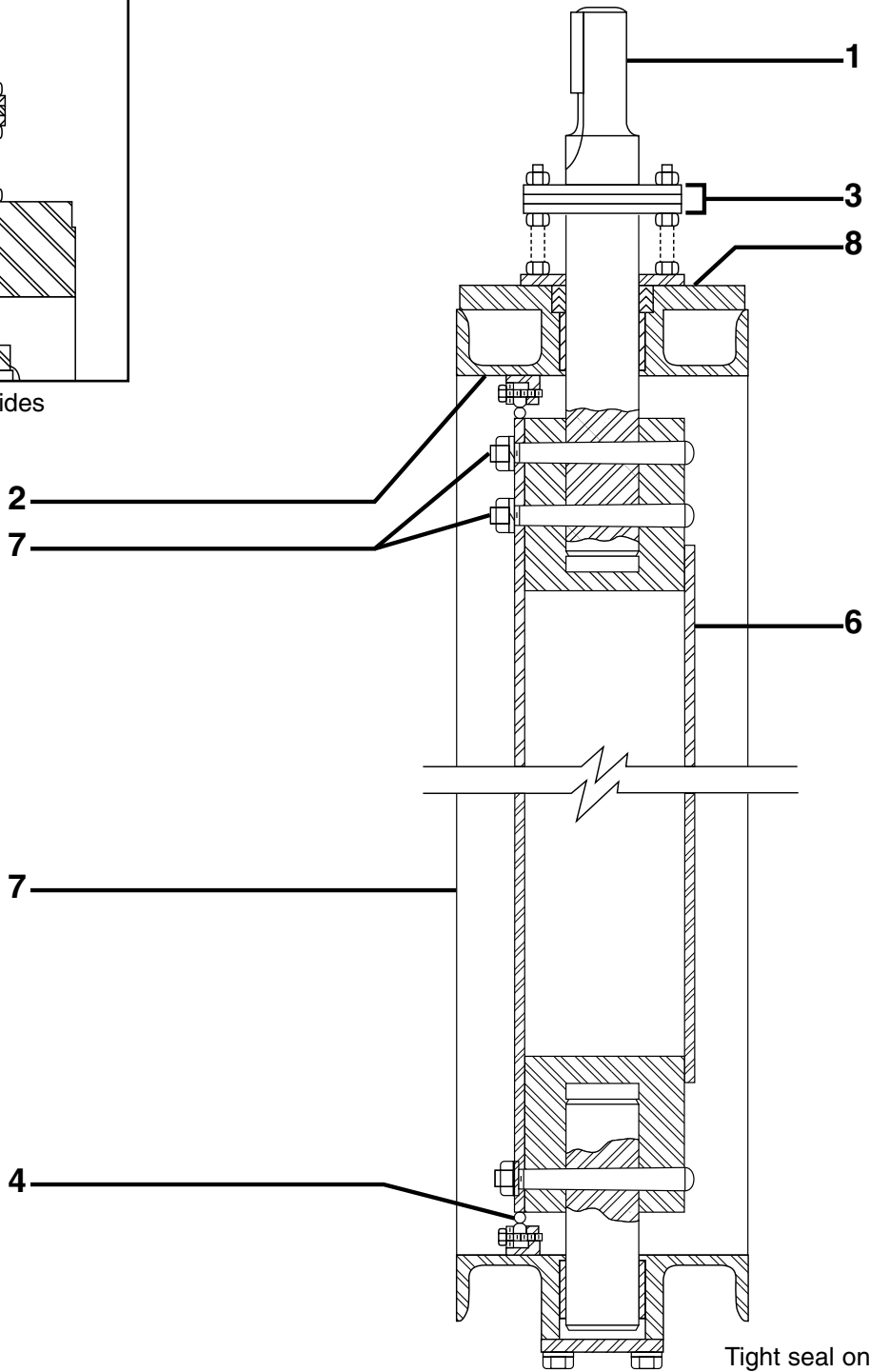

Tight seal on 4 sides

Rectangular Butterfly Gates



1) Corrosion Resistant Shafts

To prevent corrosion of a vital structural component, shafts are constructed of centerless ground, ASTM A276, Type 304 stainless steel bar -- not carbon steel or similar materials that afford no protection against the harmful effects of corrosion. Our standard line consists of a two-piece, stub type shaft keyed for actuator connection.

2) Packing (for 4-sided gates)

Packing is of the self adjusting "V" type. A packing gland or shaft seal is utilized only in the top trunnion of the gate body where the shaft protrudes for actuator connection. The packing assembly incorporates a nylon packing retainer followed by several rings of packing. It is readily accessible without having to dismantle the gate.

3) Bearings

Self lubricating sleeve type bearings are used in both trunnions of the gate body. Bearings support the shaft and provide minimum friction during shaft rotation. Size and quantity of bearings are dependent on shaft diameter and gate pressure rating. Bearing material is of a teflon lined, fiberglass backed compound called Duralon. This type of bearing offers electrical insulating qualities between the shaft/disc assembly and the gate body, thereby eliminating the possibility of galvanic corrosion. In addition to the bearings' inherent protection against corrosion, its reduced coefficient of friction requires far less operating torque than the bearing materials used in the past.

4) Rubber Seat

The seat is constructed of a specially compounded synthetic rubber chosen carefully for the type of service typically required of Hydro Gate butterfly gates. The 50 durometer material is highly resistant to abrasion and chosen for long life without leakage. The seat is fully adjustable and field replaceable without dismantling the actuator, disc or shaft. It is retained in the body by ASTM A276, 18-8 Type 304 stainless steel segments and screws to ensure bubble tight closure after many years of demanding service.

5) Taper Pins

The disc-to-shaft connection is accomplished by conservatively sized stainless steel taper pins, threaded at one end and secured with lockwashers and nuts. Through-pin design, with two pins at the top and one at the bottom, provides the tightest possible connection between the shaft and disc. This gives one-piece rigidity to the connection.

6) Disc

The disc is constructed of ASTM A36 carbon steel with an ASTM A276, Type 304 stainless steel seating edge. It features stress safety factors of three on the yield and five on the ultimate strength of the material. The disc is of a streamline design to prevent turbulence in the full open position and to minimize pressure drop across the gate. It also provides excellent throttling characteristics.

7) Body

The body is fabricated of carbon steel containing the seat assembly. It is designed for either wall mounting, channel mounting or installation in steel ducting.

8) Thrust Bearing Assembly

Located in the top trunnion, the 2-way thrust bearing is fully accessible from the top of the gate, if adjustment should ever be necessary. When the gate is installed in open channels, it is unnecessary to have special framing of concrete shapes at the bottom of the channel for access.

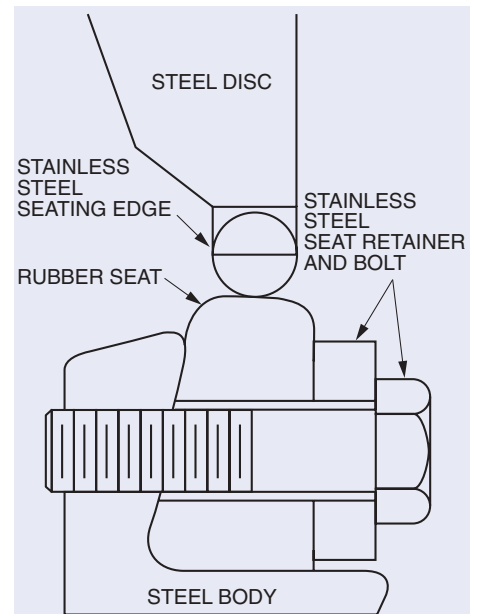

The seat is retained in the gate body by stainless steel segments and screws. Seat adjustment up to 1/4 inch is possible to ensure bubble tight closure over the life of the gate.

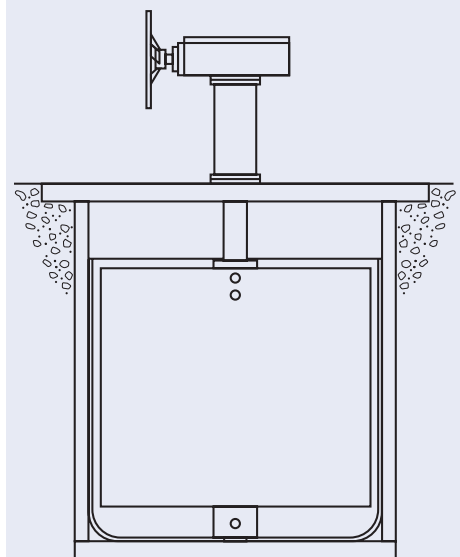

The three-sided rectangular butterfly gate features sealing surfaces on the bottom and both sides for installation in open channels. A bridge structure across the top is supplied to support the gate actuator. Cost reductions can be realized with this version since it eliminates much of the hardware and setup required for seal arrangements.

Jack Bolt Mounting System

Simple and Cost Effective Mounting

Jack bolt installation is simple, fast and economical. In this method, a channel is cast into concrete to the approximate outside dimensions of the gate. A steel channel section may also be furnished to provide for existing channel installation. The gate need not be present at the job site for this operation to be completed.

Jack bolt installation of a Hydro Gate rectangular butterfly gate is accomplished by placing the complete gate, including actuator, into a cast channel. Jack bolts, which have been screwed into the gate body, are then turned out until the gate is tightly in place. The opposite end of the gate bears against a rubber gasket. If a steel channel has not been imbedded into the concrete, the jack bolts are turned out against a steel

bearing plate that can be supplied by Hydro Gate and put in place when the gate is installed. No further on site assembly is required.

In addition to minimizing the cost of installation, this method allows the user the ability to rapidly and inexpensively remove the gate from the channel if required for plant modifications.

This installation method does not require bolting to a thimble and eliminates the need for (and cost of) a thimble or mounting frame. Concrete work need not be delayed while waiting for frames or other hardware to arrive at the jobsite, making jack bolt mounted Hydro Gate rectangular butterfly gates less costly and easier to install than other similar products.

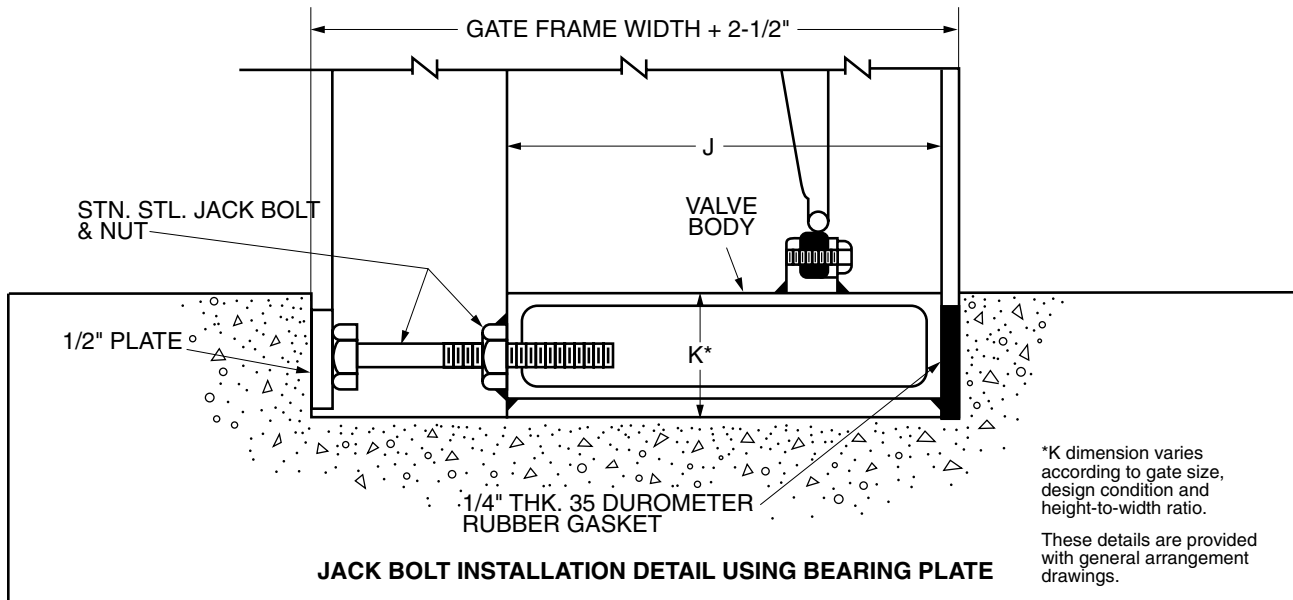

Wall Thimble Mounting System

A Mounting Method to Meet Your Requirements

Two methods of wall mounting are available. One employs a double flange thimble, the other a single flange thimble. Both thimbles are of fabricated steel construction.

With the double flange thimble, one flange of the thimble is imbedded in the concrete while the gate bolts to the other flange. No keys or anchors are necessary.

With the single flange thimble, anchors or keys are welded around the periphery of the flangeless end and bolts are welded to the flange end. Concrete is poured around the flangeless end and the anchors or keys provide firm positioning. With this method, the gate is nearly flush with the wall.

Whichever mounting method is employed, the Hydro Gate rectangular butterfly gate provides long life, quality of workmanship and superior design features to meet your plant's special flow control requirements.

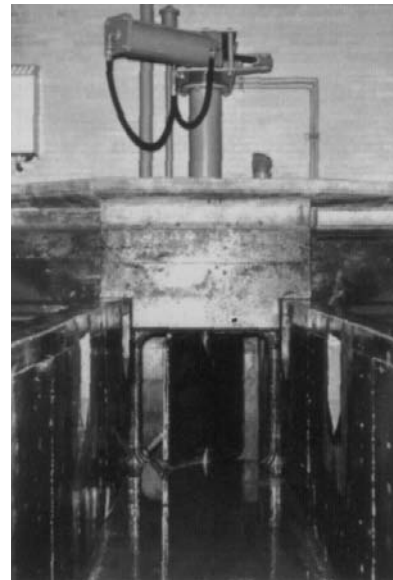
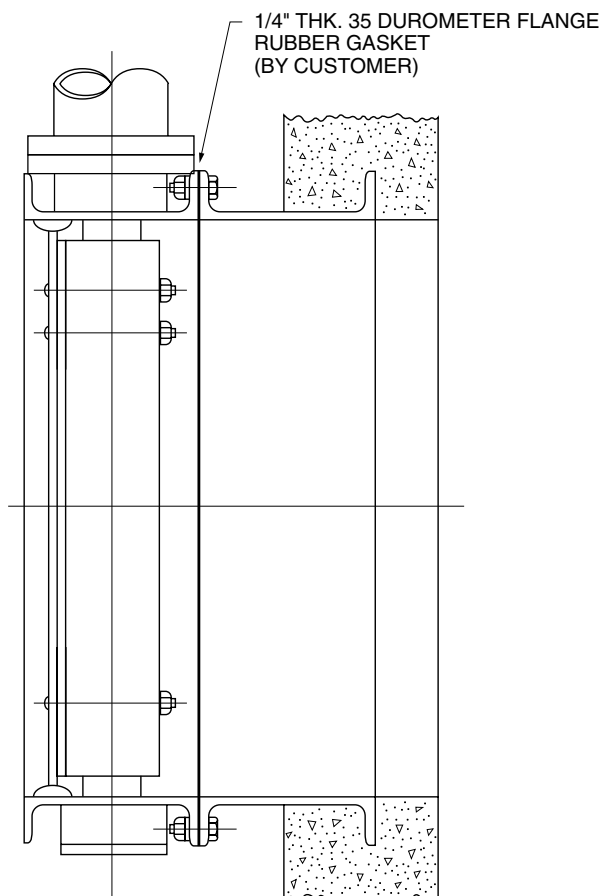

A 4ft. x 4ft. hydraulically actuated Hydro Gate rectangular gate is used in a typical filter drain application.

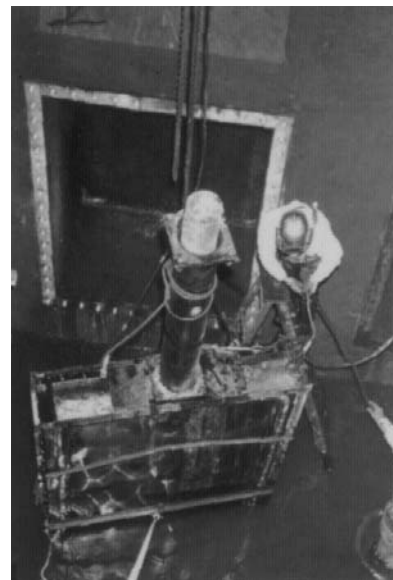

A 6ft. x 8ft. Hydro Gate rectangular gate is one of four raw water intake gates being installed in a water filtration plant.

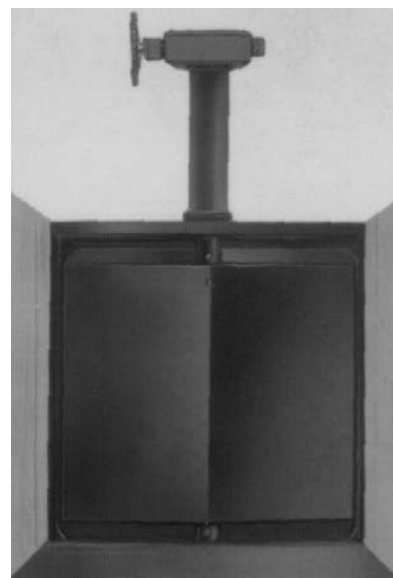

This 8ft. x 8ft. Hydro Gate rectangular gate installed in a concrete channel illustrates the jack bolt installation method.

Water Flow Characteristics

As with all of our products, the Hydro Gate rectangular butterfly gate was tested in our laboratory to determine the flow characteristics of the gate in the full open position. We perform this testing to help our customers meet their special operating requirements. The following information represents the flow characteristics of the sizes most commonly ordered. (gate sizes shown in inches)

Full Open Cv Values (x1000)

Dimensions	30	36	42	48	54	60
30	67.5	81.0	94.5	108.0	121.5	135.0
36	81.0	97.2	113.4	129.6	145.8	162.0
42	94.5	113.4	132.3	151.2	170.1	189.0
48	108.0	129.6	151.2	172.8	194.4	216.0
54	121.5	145.8	170.1	194.4	218.7	243.0
60	135.0	162.0	189.0	216.0	243.0	270.0

Notes:

- Dimensions shown in inches.
- For additional information regarding flow characteristics, please consult factory.
- Cv values for other gate sizes available upon request.

Gate Dimensions: Three Sided Rectangular Butterfly Gates

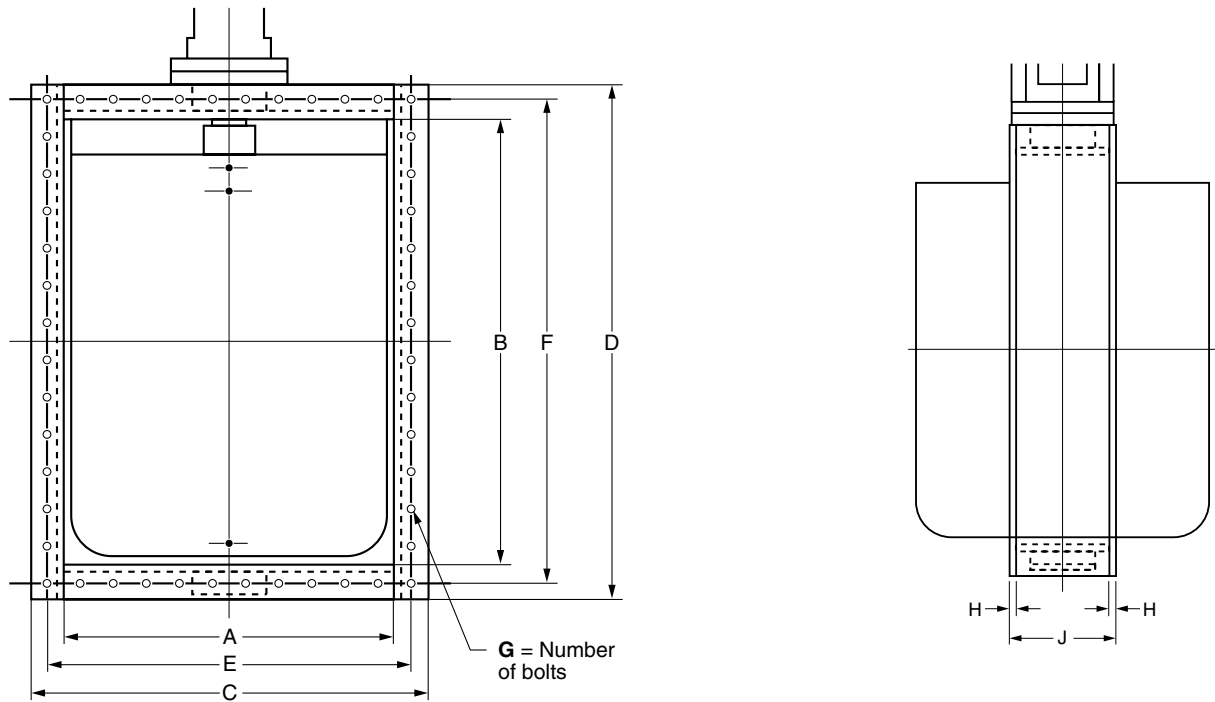

Three Sided Dimensions

Gate Size Width x Height	A	B	C*	D*	E	F	G	H	J	K
36 x 36	36	36	42	42	39 1/2	39 1/2	DETERMINED ON APPLICATION	1/2	12	3 1/4
48 x 48	48	48	54	54	52	52		1/2	12	3 1/4
60 x 60	60	60	66 3/4	66 3/4	64	64		5/8	15	3 1/4
60 x 72	60	72	66 3/4	78 3/4	64	76		5/8	15	3 5/8
72 x 96	72	96	80	104	77	101		5/8	18	4 7/8
84 x 108	84	108	92 1/2	116 1/2	89	113		5/8	18	5 3/8
144 x 144	144	144	152	152	149	149		5/8	18	5 7/8

Notes:

- Dimensions shown in inches.
- *C and D dimensions may vary with pressure and size of gate when jack bolt mounting is specified.
- G = number of 3/4 inch diameter bolts required.
- K = shaft size.

Gate Dimensions: Four Sided Rectangular Butterfly Gates

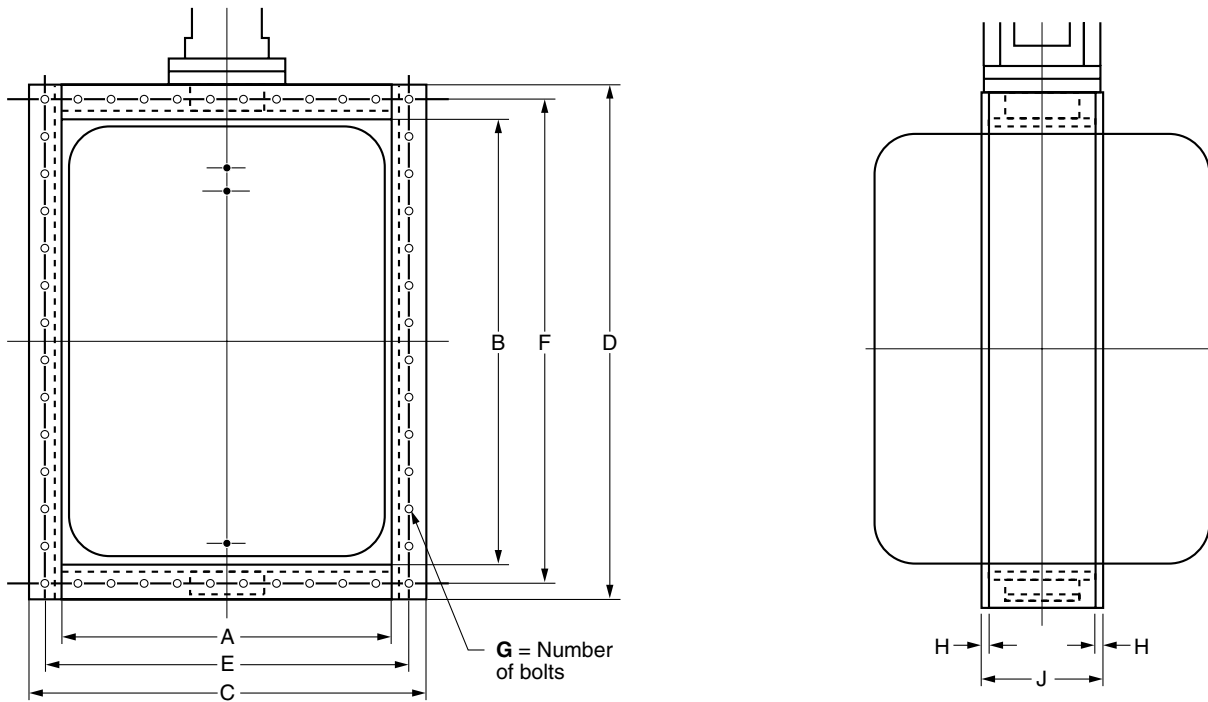

Four Sided Gate Dimensions

Gate Size Width x Height	A	B	C*	D*	E	F	G	H	J	K
36 x 36	36	36	42	42	39 1/2	39 1/2	DETERMINED ON APPLICATION	1/2	12	3 1/4
48 x 48	48	48	54	54	52	52		1/2	12	3 1/4
60 x 60	60	60	66 3/4	66 3/4	64	64		5/8	15	3 1/4
60 x 72	60	72	66 3/4	78 3/4	64	76		5/8	15	3 5/8
72 x 96	72	96	80	104	77	101		5/8	18	4 7/8
84 x 108	84	108	92 1/2	116 1/2	89	113		5/8	18	5 3/8
144 x 144	144	144	152	152	149	149		5/8	18	5 7/8

Notes:

- Dimensions shown in inches.
- *C and D dimensions may vary with pressure and size of gate when jack bolt mounting is specified.
- G = number of 3/4 inch diameter bolts required.
- K = shaft size.

Suggested Specifications for Hydro Gate Rectangular Butterfly Gates

General

All rectangular butterfly gates shall be rubber seated and shall be ___ in height and ___ in width. They shall be bubble tight at rated pressures with flow in either direction. Gate design shall be suitable for an operating differential pressure of 10 psig maximum. They shall be capable of gate operation after long periods of inactivity. Gate discs shall rotate 90 degrees from the full open position to the tight shut position. When subjected to the maximum design head, a stress safety factor of 3.0 on the yield point or 5.0 on ultimate strength, whichever is the lower, shall not be exceeded. Maximum deflection of the gate structural design limit shall be 1/32". Because of the nature of the service, experimental units or developmental designs will not be allowed. Bidders shall demonstrate a minimum of 5 years successful operation in installations and shall submit a list of such installations upon request. Gates shall be as manufactured by the Hydro Gate Company.

Gate Body and Flanges

The gate body shall be a rectangular fabrication of carbon steel ASTM A36. Upper trunnion shall be recessed and bored for chevron v-type packing. Gate bodies shall be designed for wall mounting to existing wall thimble or jack bolt mounting.

Gate Disc

The gate disc shall be fabricated of carbon steel with a stainless steel seating edge. Seating edge shall be ASTM A276 Type 304 stainless steel and shall be ground, polished and contoured. Leakage at corners under specified conditions or tests shall be cause for rejection. Disc shall be streamlined in shape to prevent turbulence in the full open position and to minimize pressure drop across the gate. Exposed disc rib stiffeners are not acceptable.

Gate Seat

The seat shall be contained in the body of the gate. Retaining segment and retaining screws shall be of ASTM A276 Type 304 stainless steel. The seat shall be a 50 durometer synthetic rubber compound. Seat adjustment possible and inherent in the design shall not be less than 1/8 inch. Gate seats shall be fully field adjustable and replaceable without dismantling the actuator, disc or shaft. The gate manufacturer shall certify that the rubber seat is fully field adjustable and replaceable without the use of special tools or processes, as well as adjustable from both sides of the disc.

Gate Shafts

Gate shafts shall be the stub type with shafts extending into the disc for a minimum distance of at least 1.5 shaft diameters. Shafts shall be securely locked to the disc by stainless steel taper pins. Shaft material shall be ASTM A276, Type 304 stainless steel.

Gate Bearings

Main shaft bearings shall be teflon lined, fiberglass backed sleeve type fitted into each gate body trunnion bore. Unit bearing stress shall not exceed 4000 psi. Each gate assembly shall be furnished with a 2-way thrust bearing assembly designed to hold the disc centered in the gate seat at all times. Thrust bearing shall be secured by a locking device, located in the top trunnion of the gate body and easily accessible for field adjustment from the actuator end of the gate.

Installation

Gates designed for channel installation shall be installed to provide a means of removing the complete gate assembly without dismantling the gate or actuator. Installation methods that employ permanent, multiple bolting shall not be acceptable for channel mounting. Gates designed for wall mounting shall have flanges drilled in accordance with the template of a frame or casting to which it is bolted. Gates installed in ducting shall have body flanges suitable for welding to steel ducting or drilled for bolting to duct flanges.

Painting

Two coats of paint shall be applied to the inside and outside surfaces of the gate body and the outside surfaces of the disc, except finished surfaces, bearing surfaces and the stainless steel seat retainers and disc edge. The paint shall be either asphalt varnish (per Federal Specifications TT-C494A) for sewage service or where additional protection is desired. Rust inhibitive alkyd primer shall be applied for fresh water, steam or air service.

Actuation: Rectangular Butterfly Gates

Traveling Nut Type Manual Actuator

When manual actuation is required, the Hydro Gate manual compound lever-traveling nut type actuator is the ideal option for the Hydro Gate rectangular butterfly gate. This actuator provides characterized closure, minimizing the possibility of line shock by slowing down the valve travel as the gate disc approaches the closed position. The high input torque capacity (300 foot pound minimum and a 200 pound pull on the handwheel or chainwheel) provides inherent protection from actuator misuse.

The Hydro Gate manual actuator is self locking without a unidirectional sustained force from the gate. It can be relied upon to maintain exact gate position under conditions of fluctuating, turbulent and intermittent flow.

Hydro Gate's manual actuator equipped with the Hydro Gate rectangular butterfly gate, offers single source responsibility and reliability for both actuator and gate.

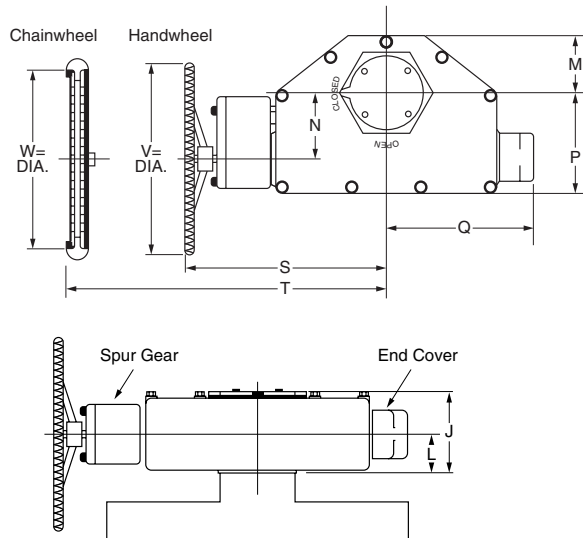

Actuator Mounting Positions

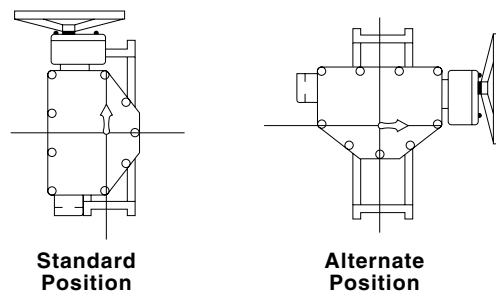

Notes:

- Clockwise to close (open left) unless otherwise specified.
- Spur gear and end cover apply only to size 6S.

Actuator Size	DIMENSIONS										
	J	L	M	N	P	Q	R	S	T	V	W
3	7 3/4	2 7/16	3 1/4	3 5/22	5 5/8	5 3/8	9 1/4	10 1/2	10	12	9 1/8
4	8	2 13/16	3 3/8	4	7 5/16	6 3/4	10 1/2	11 1/2	11	12	9 1/8
5	10	3 13/16	4 1/2	5 1/2	8 3/4	10	17	17 1/8	17 7/8	18	16 7/16
5S	10 3/4	4 5/16	5 5/8	7	10 5/8	15 15/16	19 11/16	20	20 3/4	24	22 1/4
6S	12 7/8	5 7/16	7	8 1/4	12 5/8	18 5/8	26 1/2	26 3/4	25 7/8	24	22 1/4

**The Hydro Gate rectangular butterfly gate can be equipped with a wide range of cylinder actuators and electric motor actuators to meet your special operating requirements. Please consult our factory for additional information.*



Hydro Gate Representative Territories Listed by State

ALABAMA

Eco Tech, Inc.
Phone: 770-345-2118

ALASKA

Beaver Equipment
Phone: 425-398-8082

ARIZONA

C. R. Raleigh & Assoc.
Phone: 623-972-9238

ARKANSAS

H^oE Engineered Equip.
Phone: 918-251-2121

CALIFORNIA

Southwest Valve & Equipment (Southern)
Phone: 714-832-1090

Southwest Valve LLC (Northern)
Phone: 559-322-4715

COLORADO

Pipetone Industrial Co.
Phone: 303-771-2300

CONNECTICUT

Atlantic Fluid Tech. Assoc.
Phone: 508-755-0440

DELAWARE

John B. Atherholt, Inc.
Phone: 610-828-4140

DISTRICT OF COLUMBIA

John B. Atherholt, Inc.
Phone: 610-828-4140

FLORIDA

Eco Tech, Inc. (Panhandle)
Phone: 770-345-2118

TSC Jacobs
Phone: 813-888-5556

GEORGIA

Eco Tech, Inc.
Phone: 770-345-2118

HAWAII

CBC, Inc.
Phone: 808-263-8838

IDAHO

W-Cubed, Inc. (Eastern)
Phone: 801-466-3819

Beaver Equipment Specialty Co. (Western)
Phone: 425-398-8082

ILLINOIS

HPCO-Rich Brodhead (Northern)
Phone: 630-844-4034

Van Devanter Engineering Co. (Southern)
Phone: 636-436-8880

INDIANA

Colley & Associates
Phone: 317-254-1001

INTERNATIONAL

Stealth Valve & Controls, Ltd (Canada)
Phone: 905-845-4500

Construction Products Int'l (Middle East & Caribbean)
Phone: 281-362-0155

URBACA

(Mexico - Northern & Western)
Phone: 011-52-664-686-0699

Vanderbeken Americas (Mexico - Eastern & Southern)
Phone: 011-52-818-400-7849

IOWA

Bert Gurney & Associates, Inc.
Phone: 402-551-7995

KANSAS

Mid-America Valve
Phone: 913-642-2442

KENTUCKY

BissNuss, Inc. (Eastern)
Phone: 513-860-1630

Van Devanter Engineering Co., Inc. (Western)
Phone: 636-343-8880

LOUISIANA

Gulf States Engineering Co.
Phone: 504-243-5500

MAINE

Atlantic Fluid Technology Assoc.
Phone: 508-755-0440

MARYLAND

John B. Atherholt, Inc.
Phone: 610-828-4140

BissNuss, Inc. (Northwest)
Phone: 412-221-1200

MASSACHUSETTS

Atlantic Fluid Technology Associates
Phone: 508-755-0440

MICHIGAN

Peterson & Matz
Phone: 248-476-3204

Peterson & Matz (Upper Peninsula)
Phone: 715-355-1436

MINNESOTA

Plant & Flanged Equipment Co.
Phone: 763-792-3870

MISSISSIPPI

Gulf States Engineering Co.
Phone: 504-243-5500

MISSOURI

Mid-America Valve (Western)
Phone: 913-642-2442

Van Devanter Engineering Co. (Eastern)
Phone: 636-343-8880

MONTANA

M.E.T. Valves
Phone: 406-586-2470

NEBRASKA

Bert Gurney & Associates, Inc.
Phone: 402-551-7995

NEVADA

Southwest Valve & Equipment (Southern)
Phone: 714-832-1090

Southwest Valve LLC (Northern)
Phone: 559-322-4715

NEW HAMPSHIRE

Atlantic Fluid Technology Associates
Phone: 508-755-0440

NEW JERSEY

Atlantic Fluid Technology Associates (Northern)
Phone: 508-755-0440

John B. Atherholt, Inc. (Southern)
Phone: 610-828-4140

NEW MEXICO

Pipetone Industrial Company
Phone: 303-771-2300

NEW YORK

Atlantic Fluid Technology Associates (Southeast)
Phone: 508-755-0440

J.L. Moore, Inc.
Phone: 716-655-3433

NORTH CAROLINA

EW2 Environmental
Phone: 704-542-2444

NORTH DAKOTA

Plant & Flanged Equipment Co.
Phone: 763-792-3870

OHIO

BissNuss, Inc. (South)
Phone: 513-860-1630

BissNuss, Inc. (East)
Phone: 412-221-1200

BissNuss, Inc. (North)
Phone: 440-871-8394

OKLAHOMA

H^oE Engineered Equip. Co.
Phone: 918-251-2121

OREGON

Beaver Equipment
Phone: 503-631-8905

PENNSYLVANIA

BissNuss, Inc. (Western)
Phone: 412-221-1200

John B. Atherholt, Inc. (Eastern)
Phone: 610-828-4140

RHODE ISLAND

Atlantic Fluid Technology Assoc.
Phone: 508-755-0440

SOUTH CAROLINA

EW2 Environmental
Phone: 704-542-2444

SOUTH DAKOTA

Plant & Flanged Equipment Co.
Phone: 763-792-3870

TENNESSEE

Eco Tech, Inc.
Phone: 770-345-2118

TEXAS

Hartwell Environmental Corp. (Central and North)
Phone: 281-351-8501

Pipetone Industrial Co., Inc. (Western Edge)
Phone: 303-771-2300

UTAH

W-Cubed, Inc.
Phone: 801-466-3819

VERMONT

Atlantic Fluid Technology Assoc.
Phone: 508-755-0440

VIRGINIA

Engineered Systems & Products (Southern)
Phone: 804-271-7200

John B. Atherholt, Inc. (Northern)
Phone: 610-828-4140

WASHINGTON

Beaver Equip. Specialty Co., Inc.
Phone: 425-398-8082

WEST VIRGINIA

BissNuss, Inc. (Southern)
Phone: 304-346-7532

BissNuss, Inc. (Northern)
Phone: 412-221-1200

WISCONSIN

Peterson & Matz (eastern)
Phone: 715-355-1436

Plant & Flanged Equipment Co. (Western)
Phone: 763-792-3870

WYOMING

Pipetone Industrial Co., Inc.
Phone: 303-771-2300

CIVIL REPRESENTATIVE

States: AL, AZ, GA, KY, LA, TN

Hydro Con, Inc.
Phone: 901-755-8806

***Our mission is to be
the leading water
control gate
manufacturer in
the world,
through continuous
development of
an organization
which promotes
extraordinary customer
service, superior
engineering, quality
products and
on-time delivery.***

Hydro Gate

***Your Source for Water
Control Gates***



**Toll Free 800-678-8228
303-287-8531 (fax)
www.hydrogate.com**