

PRATT

Henry Pratt Company

Henry Pratt Series 300 Plunger Valves



**Engineering Creative Solutions
for Fluid Systems Since 1901**

A Tradition of Excellence

With the development of the first rubber seated butterfly valve more than 70 years ago, the Henry Pratt Company became a trusted name in the flow control industry, setting the standard for product quality and customer service. Today Pratt provides the following range of superior products to the water, wastewater and power generation industries.

Butterfly Valves: from 3" to 162"

Rectangular Valves: 1' x 1' to 14' x 16'

Ball Valves –

Rubber Seated: from 4" to 60"

Metal Seated: from 6" to 48"

Plug Valves: from 1/2" to 36", 3 ways

Hydraulic Control Systems

Valve Controls

**Energy Dissipating Valves
and Fixed Energy Dissipaters**

Cone Valves

Check Valves

Plunger Valves

A Commitment to Meeting The Customers' Needs

Henry Pratt valves represent a long-term commitment to both the customer and to a tradition of product excellence. This commitment is evident in the number of innovations we have brought to the industries we serve. In fact, the Henry Pratt Company was the first to introduce many of the flow control products in use today, including the first rubber seated butterfly valve, one of the first nuclear N-Stamp valves, and the bonded seat butterfly valve.

Innovative Products For Unique Applications

Though many of the standard valves we produce are used in water filtration and distribution applications, Pratt has built a reputation on the ability to develop specialized products that help customers to meet their individual operational challenges.

Creative Engineering for Fluid Systems

Pratt's ability to provide practical solutions to complex issues is demonstrated by the following case histories.

Earthquake Proof Valves

Pratt designed and manufactured hydraulically actuated valves for a water storage application so that the valves would automatically operate in the event of earthquakes. This led to the development of a valve that will withstand acceleration forces of up to 6g's.

Custom Actuation/Isolation Valves

Pratt designed and manufactured valves that would isolate a working chamber in the event of a nuclear emergency during the decommissioning of armed nuclear warheads. The valves were able to close in a millisecond using specially designed Pratt electro-pneumatic actuators.

Valves Designed for Harsh Environments

Pratt designed and manufactured a 144" diameter butterfly valve for the emergency cooling system at a jet engine test facility. The valve was designed to supply water to help dissipate the tremendous heat generated by the engines during testing.



PRATT
Henry Pratt Company

Through experience, commitment and creative engineering, Pratt is uniquely suited to provide superior products for our customers' special needs. For more information, contact our corporate headquarters in Aurora, Illinois.

Table of Contents

Pratt Series 300 Plunger Valves

Introduction and Cavitation Risk Factor.....	2
Features and Benefits	3
Design Details/Proven Engineering.....	4-5
Performance and Control	6
Applications Overview.....	7
Design Advantages.....	8-9
Applications Overview.....	8
Dimensions and Specifications	10-11
Project Planning.....	12

Introduction to Henry Pratt Series 300 Plunger Valves: Plunger Valves – For Safe, Reliable and Exact Control

Plunger Valves are the correct valve to use whenever pressure heads or flow rates need to be safely and reliably reduced and controlled. They are used for two main tasks:

- By restricting the valve opening a change in flow conditions occurs where both flow velocity through the valve and pressure across the valve increases, resulting in conditions that create cavitation
- To be able to control the pressure and flow precisely and finely, the valve's flow control characteristics must be as linear as possible over the whole opening range.

Thanks to their well thought out design, Pratt Series 300 Plunger Valves fulfill these requirements to the greatest possible degree and are therefore the ideal valve for numerous control tasks. Butterfly and gate valves, due to their design as isolation or, open/closed valves, are not suitable for continuous use as a variable flow control valve.

New Challenges:

The production and operation of control valves requires engineering expertise and strict production controls to ensure diverse international requirements to be met:

- International standards, approvals and test regulations set the highest quality requirements.
- The increased cost of energy requires optimum flow performance with minimum pressure losses to ensure economical operation.
- Valves designed for long life and low maintenance costs ensure that the personnel costs necessary for operation are minimised. All the costs incurred over the operational life of the valve (life cycle costs) must play a decisive role in the choice of product.

... And the Solutions from Pratt

The wide range of Pratt Plunger Valves, manufactured for Henry Pratt by ERHARD, founded in 1871, fills these requirements in a particular way. Innovative and customer-focused product development, state of the art engineering, production and assembly technology and continuous quality assurance throughout the production, assembly and test process take place at ERHARD, concentrated in one location – for top quality “Made in Germany” before, during and after installation.

With the implementation of using computational fluid dynamics (CFD), our team of engineers has created the most efficient plunger valve to date. All valve components have undergone CFD design review to ensure optimal flow performance. This results in precise guiding of the medium, from the inlet up to and far beyond the controlled outlet. This enables controlled energy conversion (cavitation) in the center of the pipe. A range of flow guides at the valve outlet is available for a variety of installation conditions.

Wide Range of Uses

Pratt Series 300 Plunger Valves are especially suitable for drinking water, raw water and air. Typical applications include:

- Pump start-up and control valve
- Reservoir inlet
- Control device in the bottom outlet valve of dams (with or without venting)
- Control device in the inlet and bypass of turbines
- Safety device in the bypass outlet of turbines for quick opening
- Surge anticipating device in pumping or pressurized systems.

Cavitation Risk Factor

Depending on the pressure and velocity conditions, eddy, turbulence and cavitation zones can occur in pipes and fittings which can cause vibrations, oscillations and, under certain operating conditions, can even cause material damage.

Cavitation occurs if vapor bubbles form and implode in the pipe. According to Bernoulli's law, the total energy of a flowing medium is always the same; and therefore the sum of the potential, pressure, velocity (kinetic) and lost (dissipated) energy is constant. If the flow velocity increases at a constriction, e.g. a Plunger Valve, the pressure energy

simultaneously falls. If the pressure falls below the medium's saturation vapor pressure, vapour bubbles form which further deform after the constriction. Downstream of the constriction the velocity reduces again and the pressure increases, so that the bubbles finally implode. The microjet produced as a result can hit components with high velocities and remove component material at the point of impact. Therefore, a decisive factor for the use of the Plunger Valve is for the energy conversion (cavitation) to take place in the middle of the flow stream, and away from the wall of the associated downstream pipe, which is assured by the design of the flow profile and special attachments.

Features and Benefits at a Glance

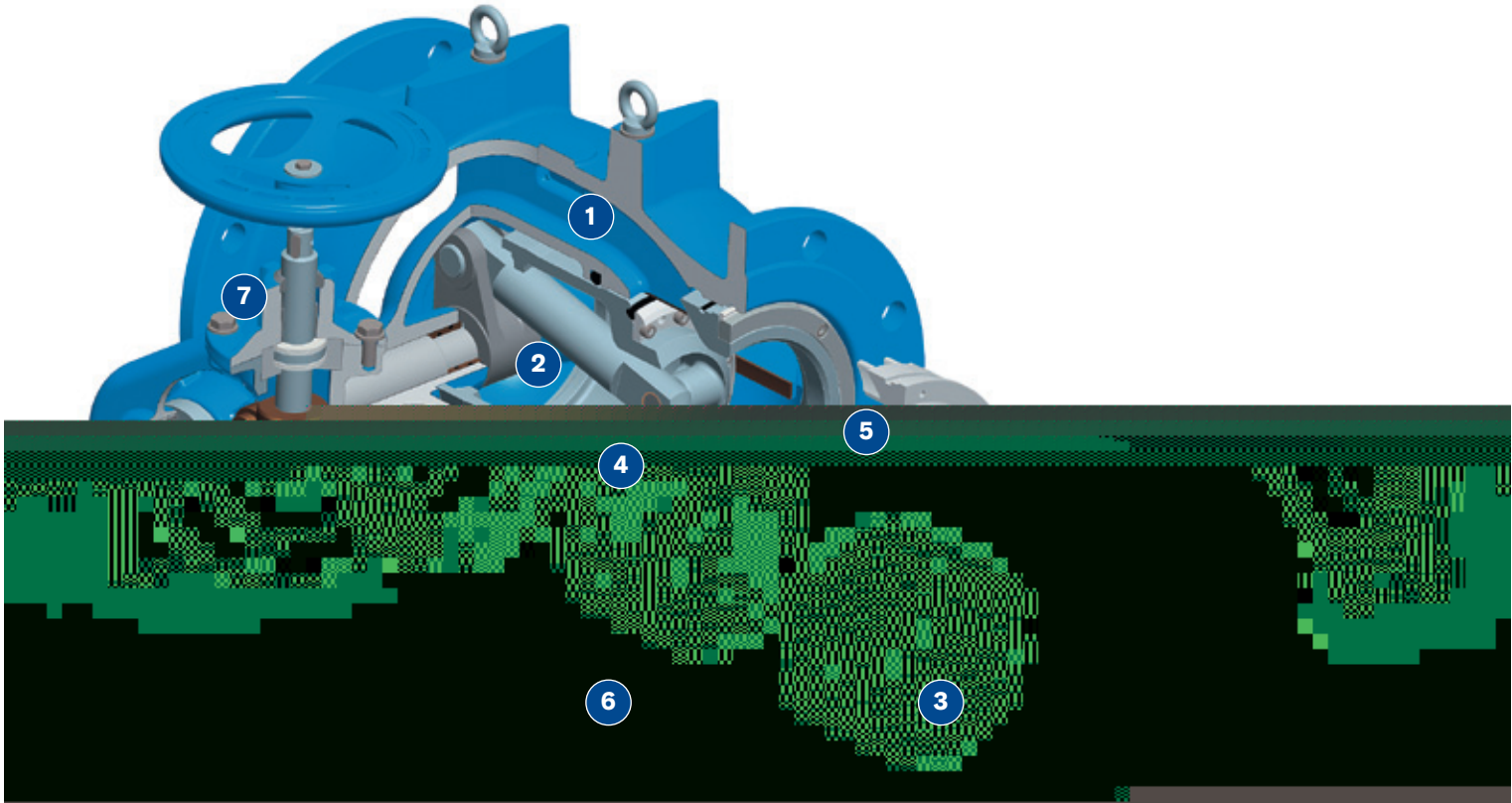

Features

1. Dual inboard seal on input shaft

Body design evaluated for efficiency with Computational Fluid Dynamic (CFD) software
2. Valve actuator mechanism utilizes a dual link and lever approach to provide a highly characterized or non-linear closure.
3. Field Replaceable control inserts to accommodate every application.
4. Main O-ring seal located on plunger.
5. Four hard faced guides to support cylinder.

Valve body coated with fusion bonded epoxy.
6. Scalable valve design for many different pressure classes and valve sizes.
7. Flexible design accommodates many forms of valve actuation and control.

Benefits

Improved corrosion protection on input shaft and shaft bore. Also provides a “dry shaft” condition eliminating water stagnation in body shaft bore.

Computer simulation and lab testing validates the Pratt plunger design to be the most flow efficient valve available today.

Effective control range is 96% of entire stroke; also provides precise surge resistant slow closure at end of close.

Effectively provides pressure reduction while controlling the damaging effects of cavitation.

O-ring stays out of cavitation zone thus ensuring many reliable years of operation.

Allows for uniform, diametrically opposite, loading and support. Four guided system has been proven to minimize wear, compared to a three guide system, in the presence of vibration.

Fusion bonded epoxy provides holiday free corrosion protection.

Pratt plunger valve will accommodate numerous special and severe service applications.

Valve can be controlled via manual operation, cylinder control, where the supply media can be water oil or air, or through electric gear actuation. The plunger valve can accept many modes of inputs such as mechanical, analog, discreet, and local control.

Proven Engineering for Diverse Tasks

The principle of the Plunger Valve

Typically the change in cross section, of any valve, is made to adjust line pressure or flow rate. Control valves such as gate valves, or other types of control valves, have an inherent asymmetrical cross section which cannot provide a linear control curve over their respective control range. The Pratt Series 300 Plunger valve features a ring shaped symmetrical cross section that enables a linear control curve over the entire control range. Initially the cross-section is steadily reduced from the inlet up to the cylinder seal ring and the flow is guided along in a geometrically optimized shape on between the valve bore and teardrop shaped internal body.

A sliding piston is axially guided inside the teardrop shaped internal body to allow for flexible and precise changes of the flow cross-section. The piston's linear movement results from conversion of the rotary movement of the actuator shaft by the internal slider crank mechanism and ensures a well defined ring-shaped cross-section in every position.

Depending on the intended use, various control inserts are mounted on the piston, which split the flow into individual flow streams for conversion of the energy. These flow streams do not hit each other until they reach the middle of the valve or pipe, which reliably prevents cavitation damage to the valve.

Designs for every purpose

Henry Pratt Series 300 Plunger Valves are available in many standard sizes and pressure classes. Selection of a control insert for a particular application (vaned ring, slotted cylinder or perforated cylinder) will be engineered and produced specific to your flow control needs. Contact the Pratt Product Manager who will help you with your specific needs.

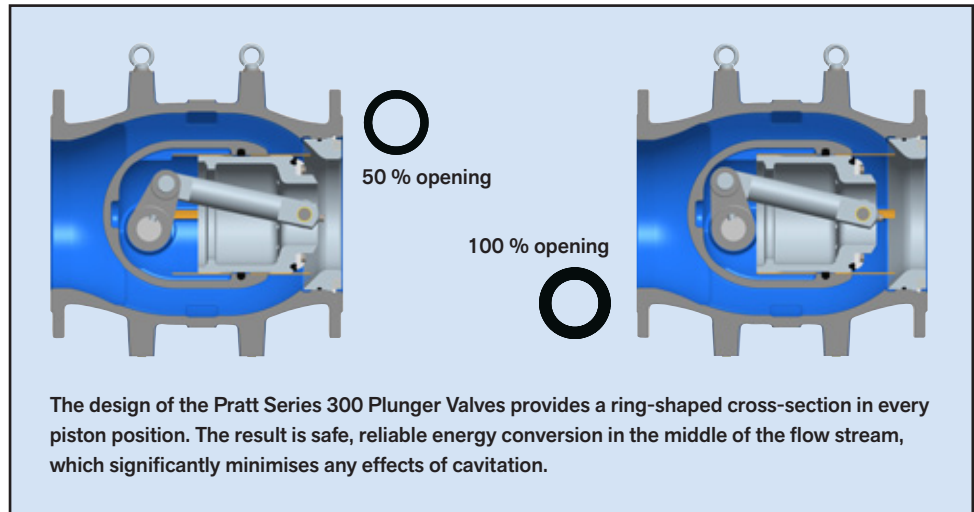

Pratt Series 300 Plunger Valves can be used for numerous important tasks including (left) the bottom outlet valve of dams as well as (right) complex control tasks.



Improper continuous use of butterfly valves as a control valve can result in dramatic material damage, as in this valve opened by 5° after a year in seawater.

Pratt Series 300 Plunger Valves can be used in numerous control applications including

- Downstream pressure control
- Upstream pressure control
- Reservoir control
- Flow control
- Tank Filling



Attention must also be paid to venting and on the positioning of the Plunger Valve. For example, if the valve is positioned directly at the end of a pipe in a bottom outlet above the water line and is equipped with a vaned ring, the energy conversion takes place by splitting up the water jet and intensive mixing with the ambient air, so that separate venting is not necessary. If on the other hand the pipe is continued downstream of the Plunger Valve below the water line, an appropriate designed increase in nominal size and a venting pipe may be required. This action will ensure adequate air supply downstream of the seat and avoid enormous cavitation and imploding forces that could result in damage. Your Henry Pratt team will provide you with competent and comprehensive design application advice.

Depending on the nominal size and design, Pratt Series 300 Plunger Valves are available as single or multipart types.

Short body version (SBVE)

In special installation situations a shorter face to face version may be required. The SBVE version is a viable option when high pressure ratings have to be dissipated (without the focus being on maximum flow) or if confined space conditions exist. Consult Pratt to inquire on special face to face applications.

All Henry Pratt Plunger Valves up to 12" are coated with a fusion bonded epoxy coating as a standard feature. Fusion bonded epoxy coating is an optional adder for valve exteriors up to 42" and interiors up to 24". This epoxy coating, applied using powder coating methods, is one of the most frequently used corrosion protection methods. The cast parts are first shot-blasted to a new white blast. [1]. The coating is then applied with a precisely defined thickness in the electrostatic power station and is fusion bonded at 410 °F. The standard coat thickness is at least 10 Mils, coat thicknesses up to 20 Mils are possible. The standard coating that is applied to large valves (larger than 12") uses a two part liquid epoxy. The low solvent 2 part

liquid coating is electrostatically applied over zinc rich primer. [2].

Other special coatings are available for particular requirements, e.g. EPC coating (epoxy polymer ceramic) with ceramic reinforcing fillers, particularly suitable for abrasive media or seawater.



Safe and Reliable Pressure Reduction and Cavitation Under Control

Pratt Series 300 Plunger Valves are fitted with a standard seat ring as basic equipment. This general purpose configuration is the suitable solution for low resistance coefficients such as air handling applications.

For other applications, special control inserts matched to the particular operating conditions are recommended. The unique designs for these inserts are further examples of the adaptability and high performance results you can expect from the Series 300 Plunger Valve. The proper insert ensures that the velocity increase that occurs when the cross-section is changed does not result in cavitation damage. The choice of the correct control insert depends on the operating conditions, the differential pressure and the resulting cavitation behaviour. We would be happy to review your application and offer the proper control solution.

Vaned ring

The vaned ring features uniformly arranged blades that split the flow into individual flow streams just before the sealing point and due to their shape sets these flow streams into a spiral movement.

The outer flow is pressed against the wall of the outlet part or the downstream pipe so that the cavitation bubbles which occur do not come anywhere near the wall, but instead are bundled together to form a "pigtail" in the middle of the pipe. There they are dissipated without causing any damage. Vaned rings are used for average pressure differences and in back-pressure situations.

Slotted cylinder

Slotted cylinders, on the other hand, are the recommended design for high pressure differences.

This attachment extends the end piston in a similar way to a pipe and is especially designed for specific operating conditions. The water jets flowing from the outside to the inside through the slots are split up at the slots and reach a high velocity. Then, in the material-free center of the cylinder, they collide with the jets emerging from the slots on the opposite side. The induced collision converts part of the kinetic energy into pressure energy.

The cavitation bubbles occurring at the slots and dragged along with the jets are dissipated by this increase in pressure in the center of the flow without causing any damage.

Perforated cylinder

The perforated cylinder, which functions in the same way as the slotted cylinder but has a higher K value, is also suitable for high pressure differences.

Other available control inserts

- Special slotted cylinder
- Special perforated cylinder
- Throttle ring especially for energy recovery systems
- Control attachments for pump test rig
- Control inserts for bottom outlets

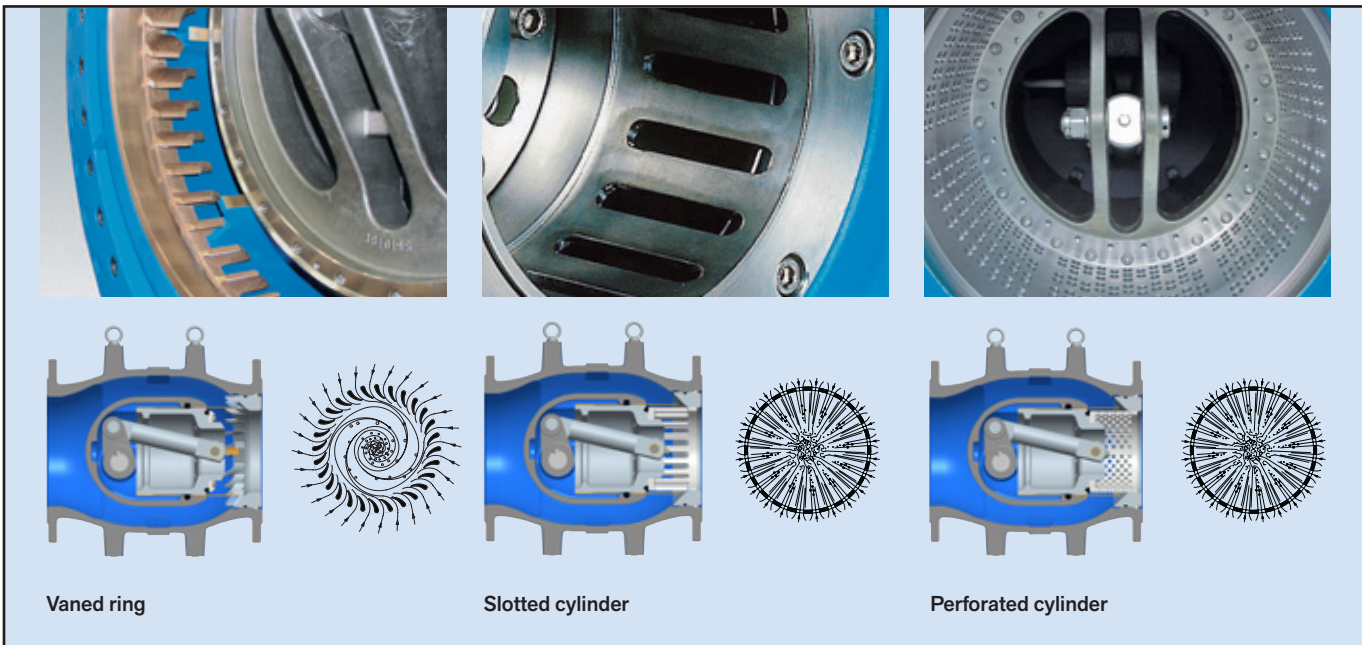

The Perfect Solution, Even for Special Requirements

Pratt Series 300 Plunger Valves are suitable for classic uses such as the bottom outlet control and safety devices in turbines and pipes as well as for numerous other specialty applications:

- Shut-off device in pipes with high operating pressure and high flow velocities
- Pump control valve
- Return flow prevention for pumps with counter weight
- Piston type check valve
- Surge anticipator valve for venting surges in the pipe system (free of auxiliary power)
- Bypass outlet surge protection in pipelines
- Pilot operated pressure-reducing valve (free of auxiliary power)
- Pipe burst protection (pressure relief)
- Turbine bypass
- Turbine control
- Filling valve for high pressures and pipe discharging in the open air or for large pipelines
- Flushing/purging valve
- Pump test rig
- Air flow rate control in aeration tanks
- Industrial applications
- Pressure control device in natural gas pipes



1



2



3



4

Henry Pratt and ERHARD are in demand worldwide as a reliable partner for projects large and small. We regularly demonstrate our expertise by achieving success in some of the most demanding and complex applications. Here are a few examples:

[1] Water power is one of the cleanest sources of energy on the earth and advanced technologies have made this resource more and more economically attractive. Our Plunger Valve with specialized control engineering was installed in the secondary turbine outlet during the rehabilitation of a river hydroelectric station. The valve operates automatically based on flow control and, if the turbines are shut down, pressure surges are internalized and therefore avoids any risk to the plant.

[2] In the storage facilities of large drinking water supply plants, geodetic energy is often available virtually free of charge. Highly reliable valves suitable for use with drinking water are required in the parts of the plant in which energy recovery is possible. An example of this type of use for Pratt valves includes a 24" Plunger Valve with weight-loaded hydraulic actuator and magnetic

clutch. Up to 19,000 gallons per minute have to be safely controlled upstream of the turbine and must be stopped reliably and without surges if the turbine is shut down. For this application, a Plunger Valve proved to be the answer.

[3] In a drinking water project in the United Arab Emirates, over 13 million cubic feet of extremely precious drinking water are distributed into desert regions daily. The distribution network includes a 112-mile pipeline, in which more than 500 valves are used, including 32 Plunger Valves with a variety of different tasks. A specially adapted version for seawater desalination plants ensures continuous, fault-free operation and required meeting (and exceeding) very high customer standards.

[4] Apart from their use in the drinking water sector, Plunger Valves are also used in the wastewater sector, in this case, for aeration control in a wastewater treatment plant.

The Advantages of the New Henry Pratt Series 300 Plunger Valves

The new Pratt Series 300 Plunger Valve incorporates numerous innovative ideas for greater economic efficiency, greater operating safety, longer life and improved controllability of the valve.

Optimized flow guidance – a positive result for economic efficiency

The flow channel of the Pratt Series 300 Plunger Valves was redesigned on the basis of years of field experience, computer modeling and verification through empirical testing.

Optimum design of the sealing and outlet components, flow-optimized component shapes and freely selectable control inserts for the user (e.g.: smooth seat rings, vaned ring, slotted cylinders, and perforated cylinders for the lowest K values) provide cost-effective operation as the pressure loss is lower.

The ingenious O-ring arrangement within the Plunger Valve also reliably avoids creating stagnant water. This design feature ensures NSF 61 compliance at all times, which is especially important for all drinking water applications.

Absolutely minimum gasket wear – a positive gain for operating safety

The wide main gasket of the Pratt Series 300 Plunger Valves is located safely in the hydraulically uncritical pressure zone and therefore in the cavitation-free space of the control valve. The sealing surface is up to 5-7/8 inches wide and is completely embedded in a stainless steel chamber and, therefore, protected against

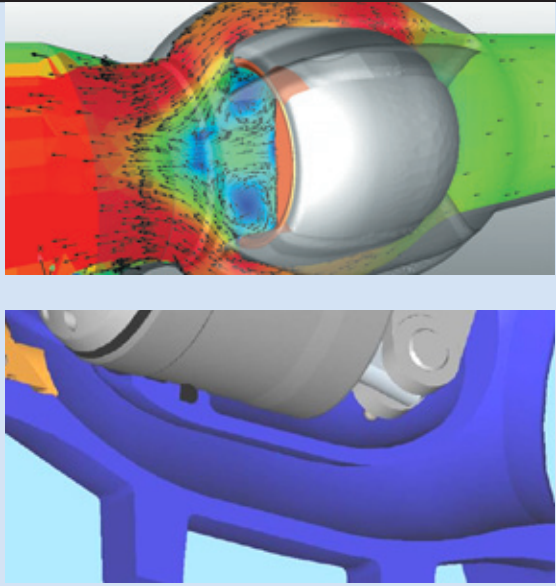

Extensive empirical testing of the Pratt Series 300 Plunger Valve provided sufficient data to corroborate the resultant output from FEA flow simulations. 3D modeling software optimized the efficiency and effectivity of the plunger valve to the greatest degree possible. Combine this engineering feat with a high precision production and assembly process, the performance values derived in controlled conditions are easily realized in typical field applications.

corrosion on all sides. The piston seal uses a solid O-ring with a proven and tested “undercut piston” design. This combination of superior features delivers an optimum sealing system developed for minimum wear.

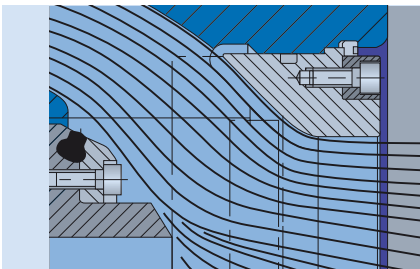

The main seal, up to 7/8 inches wide, resides on the piston periphery and recessed from direct impact of the flow media, outside the zone of cavitation and is captured in corrosion-proof stainless steel.

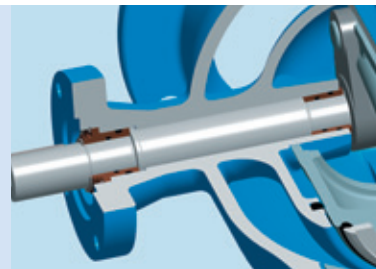

The additional shaft seal on the inside surface improves corrosion protection and avoids stagnant water.

Four surface-hardened guides – a positive result for longer life

By using four wide guide bars, the force of the weight of the piston acts vertically and due to the larger total contact area the force is also uniformly spread over the guide bars. Designs with fewer than 4 guide bars often cause non-uniform contact and result in far greater wear.

An aluminum bronze alloy was chosen because of its high hardness properties and because it is an industry-tested material that has proven its worth over decades of use in high-pressure plunger applications. The standard material thickness of about 1/8 inch has provided superior wear resistance and demonstrates good anti-friction properties for decades of operation no matter what the installation orientation might be.

Surface-hardened aluminum bronze guides also greatly increase corrosion resistance, as the homogeneous material structure does not provide any points for corrosion to attack.

Large linear control range – a positive gain for controllability

While other current Plunger Valve designs have a “dead” stroke of up to 18%, the Pratt Series 300 Plunger Valve can be precisely controlled from 4% open to full open. This optimized control of even the smallest quantities without critical annular clearance provides an impressively large control range of up to 96%.

The improved control performance is also assisted by the standard slider crank mechanism which has an optimally adjusted characteristic torque curve and therefore supplies the suitable torque in every opening angle. A slower closing speed near the “closed” position enables extremely soft closing and eliminates the risk of pressure surges.

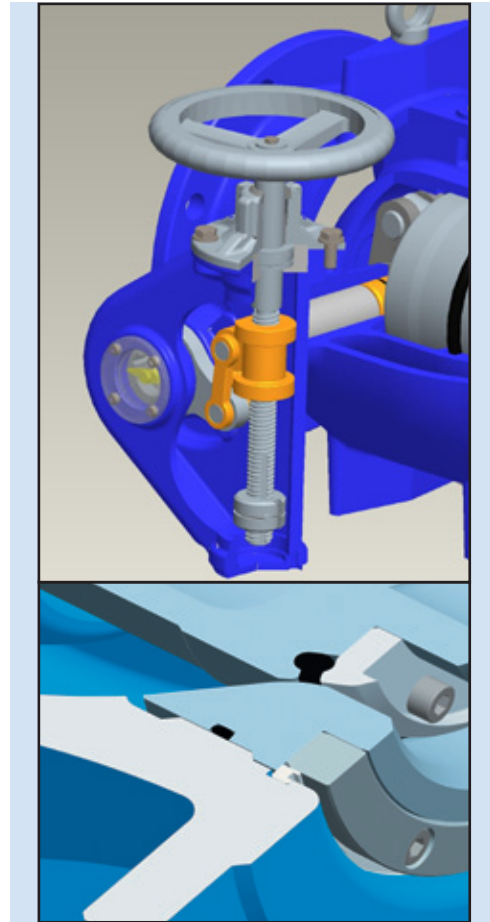

The combination of superior piston guides and a slider crank mechanism results in a control range of approximately 96%.



The four surface-hardened guides ensure uniform movement of the piston and contribute to long life.

Henry Pratt Series 300 Plunger Valves – the Dimensions Table

DIA. Inches	L	PN FLANGE and RATED WORKING PRESSURE, PSI			Linear Dimensions Shown in Inches										
		D PN10 150psi	D PN16 250psi	D PN25 350psi	h1	h2	h3 manual	h3 electric	e1	e2	e3	u #Turns	G (Lb.) PN10	G (Lb.) PN16	G (Lb.) PN25
4	12.8	--	8.7	9.3	5.6	7.4	8.7	6.1	3.9	8.4	1.1	15	132	132	132
5	12.8	--	9.8	10.6	5.6	7.4	8.7	6.1	3.9	8.4	1.1	15	132	132	132
6	13.8	--	11.2	11.8	6.2	8.0	8.7	5.7	4.6	9.1	1.9	15	165	165	165
8	15.7	13.4	13.4	14.2	7.7	9.8	9.6	6.5	6.0	11.3	2.5	20	264	264	264
10	17.7	15.7	15.7	16.7	9.2	11.7	12.4	9.2	7.4	14.4	3.1	25	418	418	418
12	19.7	17.9	17.9	19.1	10.5	12.7	12.4	9.2	8.8	15.8	4.0	25	572	572	572
14	27.6	19.9	20.5	21.9	11.0	13.5	14.2	11.5	11.0	16.5	2.6	43	935	990	990
16	31.5	22.2	22.8	24.4	12.2	14.6	14.4	11.7	12.2	18.1	2.6	42	1254	1309	1309
18	35.4	24.2	25.2	26.4	13.4	16.2	15.9	13.0	13.2	20.1	2.8	36	1716	1817	1817
20	39.4	26.4	28.1	28.7	15.0	17.8	16.1	13.2	14.6	21.5	3.9	43	1925	2079	2079
24	47.2	30.7	33.1	33.3	18.1	21.7	20.4	16.4	17.3	25.2	3.3	43	3652	3916	3916
28	55.1	35.2	35.8	37.8	21.1	25.4	22.3	18.3	20.1	28.3	3.4	57	4675	4785	4983
31	63.0	40.0	40.4	42.7	24.0	28.3	22.5	18.5	23.0	31.5	3.2	52	7150	7249	7579
36	70.9	43.9	44.3	46.7	27.6	32.6	20.9	16.9	25.8	33.9	4.4	58	9350	9482	9900
40	78.7	48.4	49.4	52.0	30.9	36.7	20.9	16.9	28.9	37.4	4.7	60	12430	12650	13200
48	94.5	57.3	58.5	60.2	37.4	44.0	22.4	18.3	34.3	43.7	4.7	78	18040	18370	18700

Dimensions used

- L [in.] Face-to-face dimensions
- D [in.] Flange
- G [lb.] weight (approximate value, differs depending on the design)
- u Handwheel revolutions (Open/Closed)

HR with handwheel
 EA with electric rotary actuator (dimensions can vary depending on the actuator manufacturer)
 Other actuator options available on request

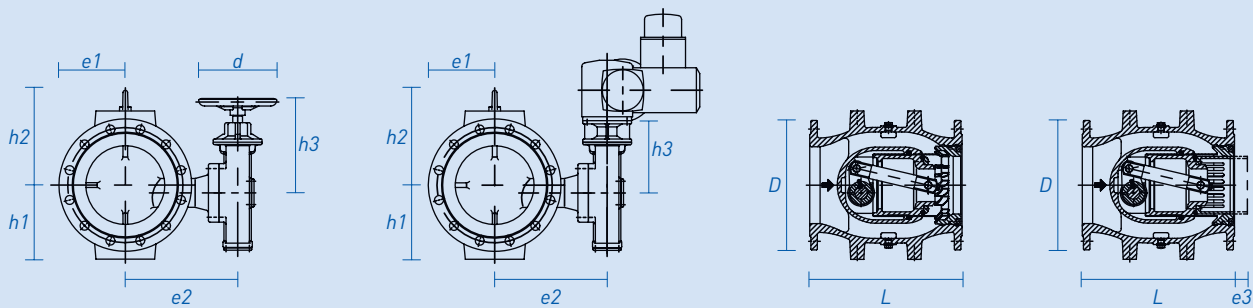

This table contains the dimensions of the standard products in the Pratt Series 300 Plunger Valve range. Numerous other designs are available on request for higher pressure ratings or special face to face dimensions.



Henry Pratt Series 300 Plunger Valves – the Overview

Brief Specifications

Materials and Finishes

- Body: 4"-12" and 14"-48"/PN 25: Ductile cast iron EN-JS 1050 superior to ASTM A536, Gr. 65-45-12, 14"-48"/PN 10-16: Grey cast iron EN-JL 1040, equivalent to ASTM A126, CL. B
- Piston guide: on strips, 4"-6": stainless steel; 8"-12": C63280 bronze, highly wear resistant; DN 14"-48" and 8"-12"/PN 40: C38000 brass
- Vaned ring, seat ring: Stainless steel/bronze
- Slotted cylinder: stainless steel
- Gaskets/seals: Elastomer, EPDM
- Piston, shaft, slider crank, push rod, bolt: stainless steel
- Gearbox body: Grey cast iron
- Gearbox crank: Ductile cast iron
- Gearbox stem: ferritic CrNi steel
- Stem nut: ASTM B427 brass
- Gearbox configuration: in flow direction "right"; "left" or other arrangements are also possible
- Corrosion protection of the body parts: Fusion Bonded Epoxy or Epoxy plastic coating, color "blue", coat thickness > 10 Mills, Contact Henry Pratt for additional coating options where required

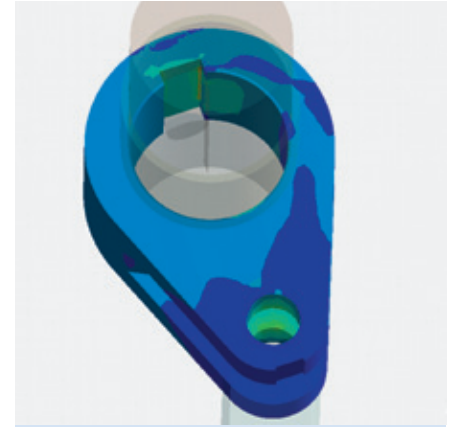

The design features of all components of the Henry Pratt Series 300 Plunger Valves reflect decades of experience combined with state of the art techniques that ensure functional development and performance in the field.

An ideal example is Pratt's use of FEA, the finite elements analysis, illustrated above.

It visualizes the stress curve in the whole component – here in the gearbox crank of a Plunger Valve – and colors it according to the existing stress: blue stands for low stresses, orange or red for high stresses. This makes it easy to see whether stress peaks occur and, if so, in which part of the component. This knowledge determines where changes are necessary to increase strength.

Notes on Project Planning and Installation

Pratt engineering support is available from your planning and design phase through to final assembly. Especially valuable is our consultation regarding correct arrangement and optimum installation of the Plunger Valve.

In most cases the advice provided will be based on your installation drawings or sketches and these will be evaluated for the best installation location of the Pratt Series 300 Plunger Valve.

For the the most accurate response, the following data is required:

- Flow rates $Q_{max.}$ and $Q_{min.}$
- Pressure p_1 upstream of the valve at $Q_{max.}$ and $Q_{min.}$
- Back-pressure p_2 downstream of the valve at $Q_{max.}$ and $Q_{min.}$
- Operating medium, any water analysis available
- Type of use (control device, bottom outlet, etc.)
- Required mode of actuation
- Operating mode (continuous or short-term operation, etc.)

You may also refer to our "Pratt Series 300 Plunger Valve questionnaire" which lists all the data required.

Installation considerations during the project planning phase (see illustration below)

1. Standard Pratt Series 300 Plunger Valves are designed for installation in horizontal or vertical pipes. It is important to confirm that the valve is installed in the pipe according to the flow arrow cast onto the pipe.

2. Nominal size reduction is possible, as Pratt Series 300 Plunger Valve are designed according to the flow velocity. We recommend achieving the transition to the pipe nominal size with abrupt extension flanges, which we can supply with the valve if required.

3. To ensure perfect operation, for velocities above 5 feet per second we recommend a straight pipe section of at least 3-5 x pipe diameters upstream and 5-10 x pipe diameters downstream of the valve, within which there must be no fittings or valves.

4. If using an adapter or extension section, wherever possible, we recommend installing it in the pipe upstream of the Pratt Series 300 Plunger Valve.

5. Plunger Valves may not be used as the pipe support. The feet cast onto the housings are solely for supporting the valve and not as a pipe fixing point. On request, Pratt Series 300 Plunger Valves are supplied with baseplates mounted on the underside.

6. When using Pratt Series 300 Plunger Valves in the bottom outlet, an appropriately dimensioned venting device (which Henry Pratt can also supply if deemed required) must be installed downstream of the valve if the valve does not flow directly into the open air.

7. When the valve flows directly into the open air a venting device is not necessary. In this case the valve should be equipped with an outlet flange only.

8. An inline fixed throttling cylinder may be used for additional pressure reduction for installation in pipes.

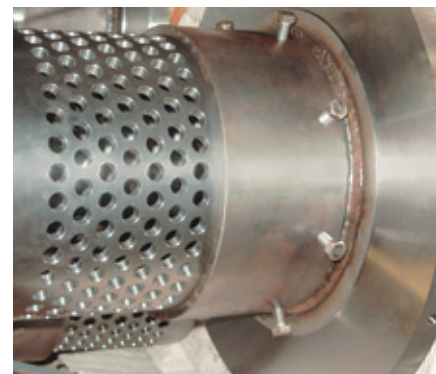
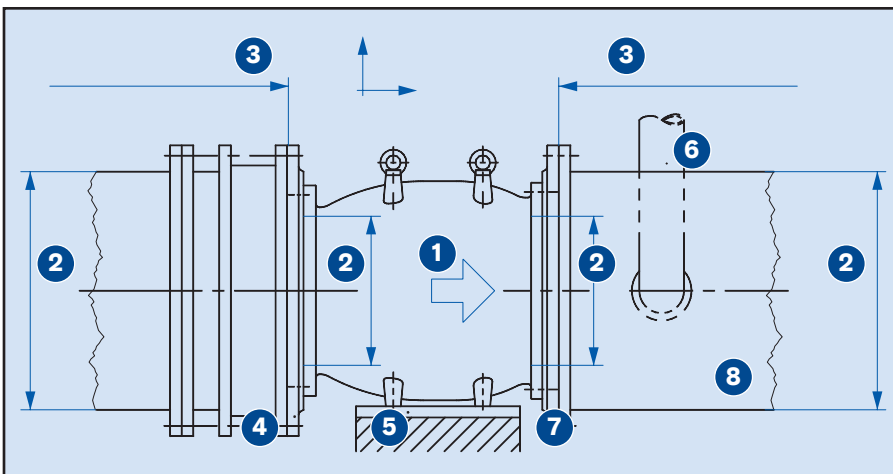

Inline fixed throttling cylinder can be installed at a distance of roughly three times the nominal size downstream of the Plunger Valve when further pressure reduction is required.

Notes

PRATT PRODUCT GUIDE



**Model
2FI**



**Monoflange
MKII**



**Plug
Valve**



**Triton®
XR70**



**Indicating Butterfly Valve
UL & FM approved**



**Tilting Disc
Check Valve**



**Triton®
XL**



**N-Stamp Nuclear
Butterfly Valve**



**Cone
Valve**



Rectangular



**PIVA Post Indicating Valve Assembly
UL & FM approved**



**Sleeve
Valve**



**Rubber Seated
Ball Valve**



**Triton®
HP250**



**Check
Valve**



**Groundhog®
Valve**



**Control
Systems**

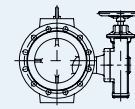

Plunger Valve

PRATT

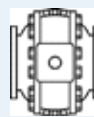

**Metal Seated
Ball Valve**

Henry Pratt Company

401 South Highland Avenue
Aurora, Illinois 60506-5563
United States
630-844-4000
Fax 630-844-4160
www.henrypratt.com
ISO 9001: 2000 Certified