

PRATT

Henry Pratt Company

AWWA Swing Check Valves

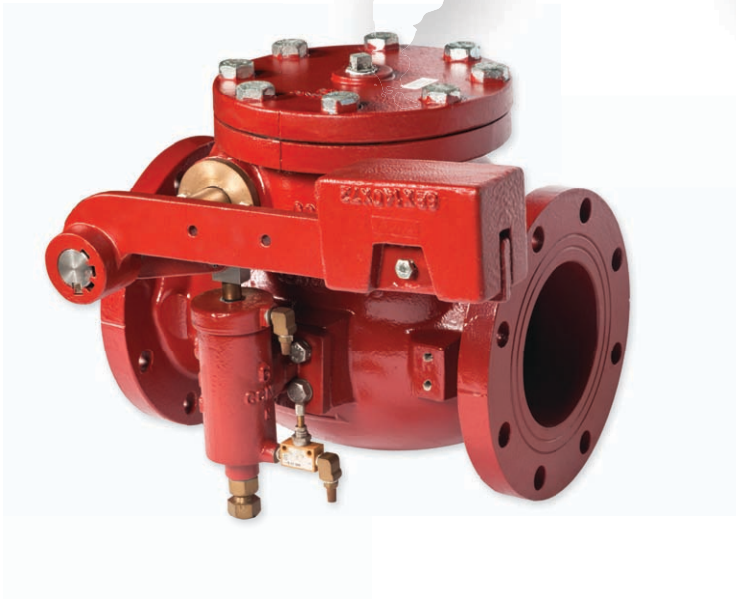

**Engineering Creative Solutions
for Fluid Systems Since 1901**

A Tradition of Excellence

With the development of the first rubber seated butterfly valve more than 70 years ago, the Henry Pratt Company became a trusted name in the flow control industry, setting the standard for product quality and customer service. Today Pratt provides the following range of superior products to the water, waste water and power generation industries.

Butterfly Valves: from 3" to 162"

Rectangular Valves: 1' x 1' to 14' x 16'

Ball Valves –

Rubber Seated: from 4" to 60"

Metal Seated: from 6" to 48"

Plug Valves: from 1/2" to 36", 3 ways

Hydraulic Control Systems

Valve Controls

**Energy Dissipating Valves
and Fixed Energy Dissipaters**

Cone Valves

Check Valves

A Commitment to Meeting The Customers' Needs

Henry Pratt valves represent a long-term commitment to both the customer and to a tradition of product excellence. This commitment is evident in the number of innovations we have brought to the industries we serve. In fact, the Henry Pratt Company was the first to introduce many of the flow control products in use today, including the first rubber seated butterfly valve, one of the first nuclear N-Stamp valves, and the bonded seat butterfly valve.

Innovative Products For Unique Applications

Though many of the standard valves we produce are used in water filtration and distribution applications, Pratt has built a reputation on the ability to develop specialized products that help customers to meet their individual operational challenges.

Creative Engineering for Fluid Systems

Pratt's ability to provide practical solutions to complex issues is demonstrated by the following case histories.

Earthquake Proof Valves

Pratt designed and manufactured hydraulically actuated valves for a water storage application so that the valves would automatically operate in the event of earthquakes. This led to the development of a valve that will withstand acceleration forces of up to 6g's.

Custom Actuation/Isolation Valves

Pratt designed and manufactured valves that would isolate a working chamber in the event of a nuclear emergency during the decommissioning of armed nuclear warheads. The valves were able to close in a millisecond using specially designed Pratt electro-pneumatic actuators.

Valves Designed for Harsh Environments

Pratt designed and manufactured a 144" diameter butterfly valve for the emergency cooling system at a jet engine test facility. The valve was designed to supply water to help dissipate the tremendous heat generated by the engines during testing.



PRATT
Henry Pratt Company

Through experience, commitment and creative engineering, Pratt is uniquely suited to provide superior products for our customers' special needs. For more information, contact our corporate headquarters in Aurora, Illinois.

Table of Contents

AWWA Swing Check Valve

Series 8001 Lever & Weight or Spring	2
Series 9001 Lever & Weight or Spring	3
Series 9001 Air Cushion Lever & Weight or Spring	4-5
Series 9001 Oil Decelerator Lever & Weight or Spring	6-7
Series 9001 Three Stage Oil Cushion Lever & Weight or Spring.....	8-9
Series 8501 Air Cushion Lever & Weight or Spring	10-11

Pratt Series 8001 AWWA Swing Check Valve Outside Lever and Weight or Spring

Series 8001 swing check valves are of self-contained, free-swinging disc style with outside lever and weight or outside lever and spring. Valves conform to all standards set forth in AWWA C508, latest edition. Suitable for use in wastewater, water, sewage, oil and gas applications. Valves are produced with cast iron body, bronze or stainless steel seat rings, Buna-N or EPDM disc inserts, and hinge pins of corrosion resistant stainless steel. Internal and external epoxy coating conforming to AWWA C550 is a standard. Valves are designed for horizontal or vertical installations and for uninterrupted continuous service.

Features/Specs

- Full waterway
- Stainless steel hinge pin
- Flanges conform to ANSI B16.1 Class 125
- Lever and weight may be installed on either side
- Valves may be installed in vertical line with flow up
- Disc seat standard with with Buna-N insert for bubble tight shut off
- Body and disc seat rings are field replaceable
- Meets AWWA C508 standards
- Low zinc bronze or stainless steel seat rings
- ANSI B16.1: Cast iron pipe flanges and flanged fittings Class 125
- AWWA C508: Swing check valves for waterworks service, 2" through 24"
- 8 mils NSF 61 epoxy in and out

Sizes: 2" - 72"

Styles: Bronze to Bronze, Bronze to Buna-N, Stainless Steel to Buna-N

Uses: Water, Sludge, Sewer Service

Test Pressures:	Size	Seat*	Shell
	2" - 12"	200psi	400psi
	14" - 72"	150psi	300psi

*rated working pressure

Size Od		ANSI B16.1 CL.125							
Inches	L	OD	OC	OH	n	T	H	H1	
2	8	6	4-3/4	3/4	4	5/8	4-15/16	3	
2-1/2	8-1/2	7	5-1/2	3/4	4	11/16	5-11/16	3-1/2	
3	9-1/2	7-1/2	6	3/4	4	3/4	6-1/16	3-3/4	
4	11-1/2	9	7-1/2	3/4	8	15/16	6-7/8	4-1/2	
6	14	11	9-1/2	7/8	8	1	8-1/2	5-1/2	
8	19-1/2	13-1/2	11-3/4	7/8	8	1-1/8	9-15/16	6-3/4	
10	24-1/2	16	14-1/4	1	12	1-3/16	11-3/16	8	
12	27-1/2	19	17	1	12	1-1/4	13-9/16	9-1/2	
14	31	21	18-3/4	1-1/8	12	1-3/8	19-5/16	12-1/16	
16	36	23-1/2	21-1/4	1-1/8	16	1-7/16	21-1/2	13-1/4	
18	40	25	22-3/4	1-1/4	16	1-9/16	25-1/8	12-1/2	
20	40	27-1/2	25	1-1/4	20	1-11/16	27	13-3/4	
24	48	32	29-1/2	1-3/8	20	1-7/8	31-5/8	16	
30	52-1/2	38-3/4	36	1-3/8	28	2-1/8	36-3/8	19-3/8	
36	60-1/2	46	42-3/4	1-5/8	32	2-3/8	40	23	

Dimensions for larger sizes available upon request.

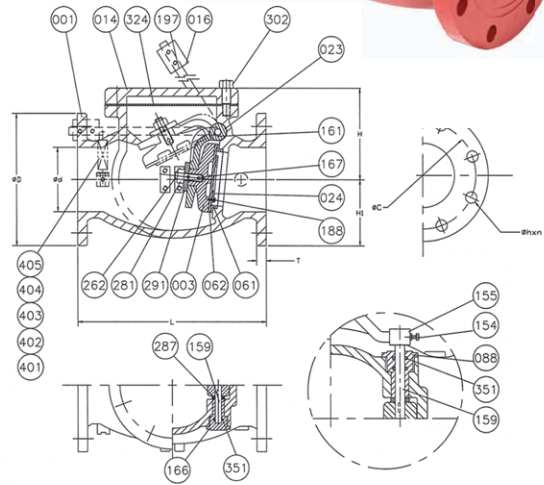

NO.	Parts	Material	ASTM Designation
405	SPRING	STAINLESS STEEL	A276 GRADE 304
404	BOLT	STAINLESS STEEL	A276 GRADE 304
403	STRAIGHT BOLT	STAINLESS STEEL	A276 GRADE 304
402	BRACKET	STAINLESS STEEL*	A276 GRADE 304
401	NUT	STAINLESS STEEL	A276 GRADE 304
351	O-RING	RUBBER (BUNA N)	D2000 BK 707
324	COVER GASKET	RUBBER (BUNA N)	D2000 BK 807
302	COVER BOLT	ZINC COATED STEEL	A307 GRADE B
291	WASHER	BRASS	B21
287	SPACER	BRASS	B21
281	DISC NUT	BRASS	B21
262	DISC STUD	BRASS	B21
197	WEIGHT BOLT	ZINC COATED STEEL	A307 GRADE B
188	DISC SEAT BOLT	STAINLESS STEEL	A276 GRADE 304
167	ROLL PIN	STAINLESS STEEL	A276 GRADE 304
166	RETAINING PLUG	BRASS	B21
161	KEY	STAINLESS STEEL	A276 GRADE 304
159	HINGE PIN	STAINLESS STEEL	A276 GRADE 304
155	WEIGHT ARM	DUCTILE IRON	A536 GRADE 65-45-12
154	BOLT W/NUT	ZINC COATED STEEL	A307 GRADE B
088	SEAT NUT	BRASS	B21
062	DISC SEAT RING	RUBBER (BUNA N)	D2000 BK 807
061	BODY SEAT RING	BRONZE	B62
024	SEAT HOLDER	2"-6" CAST IRON	A126 CLASS B
024	SEAT HOLDER	8"+ DUCTILE IRON	A536 GR 65-45-12
023	DISC ARM	DUCTILE IRON	A536 GR 65-45-12
016	WEIGHT	CAST IRON	A126 CLASS B
014	COVER	CAST IRON	A126 CLASS B
003	DISC	CAST IRON	A126 CLASS B
001	BODY	CAST IRON	A126 CLASS B

*Chrome plated steel brackets supplied on larger size valves.

**For reference ONLY. Contact Pratt for detailed sales drawings.

Pratt Series 9001 AWWA Swing Check Valve Outside Lever and Weight or Spring

Series 9001 swing check valves are self-contained, free-swinging disc style with outside lever and weight or outside lever and spring. Valves conform to all standards set forth in AWWA C508, Latest Edition. These valves feature enlarged hinge pins and upgraded materials of construction set forth for air or oil cushion valves. Suitable for use in wastewater, water, sewage, oil and gas applications. Valves are produced in cast iron body, bronze or stainless steel seat rings, Buna-N or EPDM disc inserts, and hinge pins of corrosion resistant stainless steel. Internal and external epoxy coating conforming to AWWA C550 is a standard. Valves are designed for horizontal or vertical installations and for uninterrupted continuous service. Valves are field convertible to bronze air cushion or oil cushion systems.

Features/Specs

- Clear waterway
- Enlarged stainless steel hinge pin
- Flanges conform to ANSI B16.1 Class 125
- Lever and weight may be installed on either side
- Valve may be installed in vertical line with flow up
- Disc seat standard with Buna-N insert for bubble tight shut off
- Body and disc seat rings are field replaceable
- Meets AWWA C508 standards
- Low zinc bronze or stainless steel seat rings
- Field convertible to air or oil systems
- Valves available in ductile iron (class 125/class 250)
- ANSI B16.1: Cast iron pipe flanges and flanges fittings Class 125
- AWWA C508: Swing check valves for waterworks service, 2" through 24"
- 8 mils NSF 61 epoxy in and out

Sizes: 3" - 72"

Styles: Bronze to Bronze, Bronze to Buna-N,
Stainless Steel to Buna-N

Uses: Water, Sludge, Sewer Service

Test Pressures:	Size	Seat*	Shell
	2" - 12"	200psi	400psi
	14" - 72"	150psi	300psi

*rated working pressure

Size Od		ANSI B16.1 CL.125						
Inches	L	OD	OC	OH	n	T	H	H1
3	11	7-1/2	6	3/4	4	3/4	6-3/8	3-3/4
4	13	9	7-1/2	3/4	8	15/16	7-3/8	4-1/2
6	16	11	9-1/2	7/8	8	1	9-3/16	5-1/2
8	19-1/2	13-1/2	11-3/4	7/8	8	1-1/8	10-7/8	6-3/4
10	22	16	14-1/4	1	12	1-3/16	13-5/16	8
12	26	19	17	1	12	1-1/4	15-9/16	9-1/2
14	30	21	18-3/4	1-1/8	12	1-3/8	21-1/16	12-1/16
16	30-1/2	23-1/2	21-1/4	1-1/8	16	1-7/16	24	13-5/16
18	33-1/2	25	22-3/4	1-1/4	16	1-9/16	27-9/16	14-5/8
20	40	27-1/2	25	1-1/4	20	1-11/16	31-5/16	15-3/8
24	46	32	29-1/2	1-3/8	20	1-7/8	35-1/4	17-7/8
30	60	38-3/4	36	1-3/8	28	2-1/8	36	23-1/16
36	63	46	42-3/4	1-5/8	32	2-3/8	41-15/16	27-11/16
42	70	53	49-1/2	1-5/8	36	2-5/8	46-3/4	32-1/8
48	76	59-1/2	56	1-5/8	44	2-3/4	53-1/8	35-1/2

Dimensions for larger sizes available upon request.

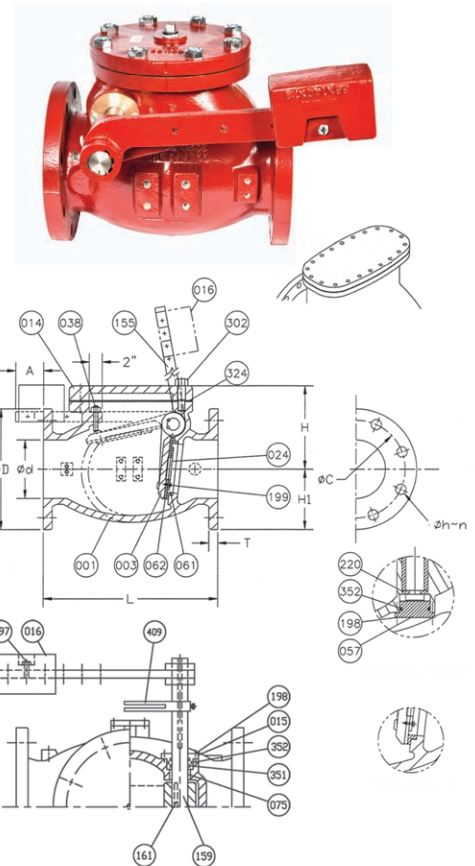

NO.	Parts	Material	ASTM Designation
409	TEAR DROP	DUCTILE IRON	A536 GR.65-45-12
352	O-RING C	RUBBER (BUNA N)	D2000 BK 707
351	O-RING B	RUBBER (BUNA N)	D2000 BK 707
324	COVER GASKET	RUBBER (BUNA N)	D2000 BK 807
302	COVER BOLT	ZINC COATED STEEL	A307 GRADE B
283	ARM BOLT	ZINC COATED STEEL	A307 GRADE B
220	SNAP RING	STAINLESS STEEL	A276 GRADE 304
199	SEAT HOLDER BOLT	STAINLESS STEEL	A276 GRADE 304
198	END PLATE BOLT	ZINC COATED STEEL	A307 GRADE B
197	WEIGHT BOLT	ZINC COATED STEEL	A307 GRADE B
161	KEY	STAINLESS STEEL	A276 GRADE 304
159	HINGE PIN	STAINLESS STEEL	A276 GRADE 304
155	WEIGHT ARM	DUCTILE IRON	A536 GR.65-45-12
075	BUSHING	BRONZE	B62
062	DISC SEAT RING	RUBBER (BUNA N)	D2000 BK 807
061	BODY SEAT RING	BRONZE	B62
057	END PLATE B	DUCTILE IRON	A536 GR.65-45-12
038	STOPPER	STAINLESS STEEL	A276 GRADE 304
024	SEAT HOLDER	3"-6" CAST IRON	A126 CLASS B
024	SEAT HOLDER	8"+ DUCTILE IRON	A536 GR 65-45-12
016	WEIGHT	CAST IRON	A126 CLASS B
015	END PLATE A	BRONZE	B62
014	COVER	CAST IRON	A126 CLASS B
003	DISC	DUCTILE IRON	A536 GR.65-45-12
001	BODY	CAST IRON	A126 CLASS B

* For reference ONLY. Contact Pratt for detailed sales drawings.

Pratt Series 9001 AWWA Swing Check Valve Air Cushion with Outside Lever and Weight or Spring

Features:

- Clear waterway
- Enlarged stainless steel hinge pin
- Flanges conform to ANSI B16.1 Class 125
- Lever and weight may be installed on either side
- Valves may be installed in vertical line with flow up
- Body and disc seat rings are field replaceable
- Disc seat standard with Buna-N insert for bubble tight shut off
- Totally enclosed bronze air cushion with stainless steel hardware
- Adjustable speed control
- Meets AWWA standards of dimensional standards of large pin cushion products
- 8 mils NSF 61 epoxy in and out

Sizes: 3" - 72"

Styles: Bronze to Bronze, Bronze to Buna-N,
Stainless Steel to Buna-N

Uses: Water, Sludge, Sewer Service



Specification for Series 9001 with Air Cushion

General: Swing check valves are of self-contained, free-swinging disc style, allowing a clear waterway. Valve disc swings freely open and is keyed to valve hinge pin without the use of pins. Valves conform to all standards set forth in AWWA C508, Latest Edition. Valve hinge pin are Stainless Steel and conform to the industry standards set forth for cushion valves. Manufacturer should have a minimum of ten years experience supplying air cushion AWWA C508 valves.

Referenced Standards:

- ANSI B16.1: Cast Iron Pipe Flanges and Flanged Fittings Class 125
- AWWA C508: Swing Check Valves for Waterworks Service, 2" through 24" NPS

Rating:

Valves are rated for 200psi on 12" and smaller, and 150psi on 14" and larger water working pressure. Valves are available in ductile iron for high pressure applications. All testing is done in accordance with AWWA C508.

End Configuration:

Valves have integrally cast flat face flanges in accordance with ANSI B16.1 Class 125.

Materials:

- All cast iron used conforms to ASTM A126 CLB
- Disc is of ductile iron conforming to ASTM A536 GR65-45-12
- Hinge Pins conform to ASTM A276 GR304
- Seat Rings are of Low Zinc Bronze conforming to ASTM B62 or of Stainless Steel conforming to ASTM A276 GR316

Coating: Internal and external coatings are two-component epoxy conforming to AWWA C550.

Design: All valves meet the standards of AWWA C508. All valves utilize a single disc mounted to a clevis hinge which prevents the disc from tipping. The valve disc swings open once the pump starts and allows for full flow. When closed the valve offers a tight shut-off. Valve body and cover are of Cast Iron, valve hinge is of Ductile Iron. Disc seating surface is either Bronze, Stainless Steel or of Buna-N depending on application. Valve seat rings are of Bronze or Stainless Steel.

The valve body has a bolted cover design and flanges are integral to body casting -not wafer style. Valve body and disc are designed in such a way as to minimize turbulence. Spring and cushion systems are externally mounted on the side of the body and do not come into contact with main line media.

Cushion systems are one-piece all bronze construction with integral pad mounted directly to the body with stainless steel fasteners. Air cushion shall consist of bronze and stainless steel components, be adjustable by means of a flow control valve and piston sleeve. Air cushion shall be totally enclosed with a metal end cap with an o-ring.

Installation: All valves are built for horizontal installation. However, all valves operate equally well in vertical installations. Prior to valve installation Pratt should be notified of vertical mounting position so lever arm and weight can be properly positioned on valve.

Pratt Series 9001 AWWA Swing Check Valve Air Cushion with Outside Lever and Weight or Spring

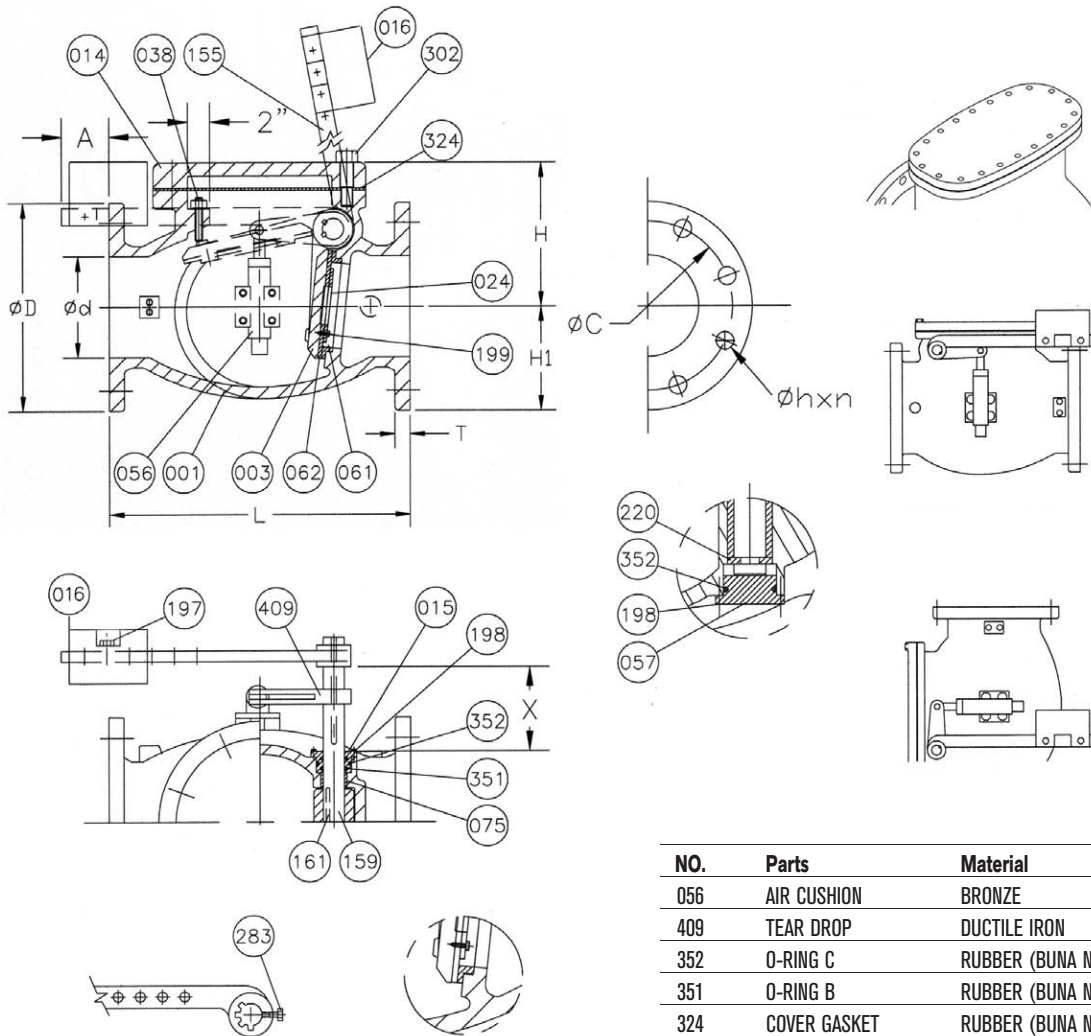

Size Od		ANSI B16.1 CL.125						
Inches	L	OD	OC	OH	n	T	H	H1
3	11	7-1/2	6	3/4	4	3/4	6-3/8	3-3/4
4	13	9	7-1/2	3/4	8	15/16	7-3/8	4-1/2
6	16	11	9-1/2	7/8	8	1	9-3/16	5-1/2
8	19-1/2	13-1/2	11-3/4	7/8	8	1-1/8	10-7/8	6-3/4
10	22	16	14-1/4	1	12	1-3/16	13-5/16	8
12	26	19	17	1	12	1-1/4	15-9/16	9-1/2
14	30	21	18-3/4	1-1/8	12	1-3/8	21-1/16	12-1/16
16	30-1/2	23-1/2	21-1/4	1-1/8	16	1-7/16	24	13-5/16
18	33-1/2	25	22-3/4	1-1/4	16	1-9/16	27-9/16	14-5/8
20	40	27-1/2	25	1-1/4	20	1-11/16	31-5/16	15-3/8
24	46	32	29-1/2	1-3/8	20	1-7/8	35-1/4	17-7/8
30	60	38-3/4	36	1-3/8	28	2-1/8	36	23-1/16
36	63	46	42-3/4	1-5/8	32	2-3/8	41-15/16	27-11/16
42	70	53	49-1/2	1-5/8	36	2-5/8	46-3/4	32-1/8
48	76	59-1/2	56	1-5/8	44	2-3/4	53-1/8	35-1/2

Dimensions for larger sizes available upon request.

NO.	Parts	Material	ASTM Designation
056	AIR CUSHION	BRONZE	B62
409	TEAR DROP	DUCTILE IRON	A536 GR 65-45-12
352	O-RING C	RUBBER (BUNA N)	D2000 BK 707
351	O-RING B	RUBBER (BUNA N)	D2000 BK 707
324	COVER GASKET	RUBBER (BUNA N)	D2000 BK 807
302	COVER BOLT	ZINC COATED STEEL	A307 GRADE B
283	ARM BOLT	ZINC COATED STEEL	A307 GRADE B
220	SNAP RING	STAINLESS STEEL	A276 GRADE 304
199	SEAT HOLDER BOLT	STAINLESS STEEL	A276 GRADE 304
198	END PLATE BOLT	ZINC COATED STEEL	A307 GRADE B
197	WEIGHT BOLT	ZINC COATED STEEL	A307 GRADE B
161	KEY	STAINLESS STEEL	A276 GRADE 304
159	HINGE PIN	STAINLESS STEEL	A276 GRADE 304
155	WEIGHT ARM	DUCTILE IRON	A536 GR 65-45-12
075	BUSHING	BRONZE	B62
062	DISC SEAT RING	RUBBER (BUNA N)	D2000 BK 807
061	BODY SEAT RING	BRONZE	B62
057	END PLATE B	DUCTILE IRON	A536 GR 65-45-12
038	STOPPER	STAINLESS STEEL	A276 GRADE 304
024	SEAT HOLDER	3"-6" CAST IRON	A126 CLASS B
024	SEAT HOLDER	8"+ DUCTILE IRON	A536 GR 65-45-12
016	WEIGHT	CAST IRON	A126 CLASS B
015	END PLATE A	BRONZE	B62
014	COVER	CAST IRON	A126 CLASS B
003	DISC	DUCTILE IRON	A536 GR 65-45-12
001	BODY	CAST IRON	A126 CLASS B

* For reference ONLY. Contact Pratt for detailed sales drawings.

Pratt Series 9001 AWWA Swing Check Valve Oil Decelerator with Outside Lever and Weight or Spring

Features:

- Clear waterway
- Enlarged stainless steel hinge pin
- Flanges conform to ANSI B16.1 Class 125
- Lever and weight may be installed on either side
- Valves may be installed in vertical line with flow up
- Body and disc seat rings are field replaceable
- Disc seat standard with Buna-N insert for bubble tight shut off
- Meets AWWA standards of dimensional standards of large pin cushion products
- 100% oil controlled system with adjustable speed control valve
- 8 mils NSF 61 epoxy in and out

Sizes: 3" - 72"

Styles: Bronze to Bronze, Bronze to Buna-N, Stainless Steel to Buna-N

Uses: Water, Sludge, Sewer Service



Specification for Series 9001 with Oil Cushion

General: Swing check valves are of self-contained, free-swinging disc style allowing a clear waterway. Valve disc swings freely open and is keyed to valve hinge pin without the use of pins. Valves conform to all standards set forth in AWWA C508, Latest Edition. Valve hinge pins are Stainless Steel and conform to the industry standards set forth for cushion valves. Manufacturer should have a minimum of ten years experience supplying oil cushion AWWA C508 valves.

Referenced Standards:

- ANSI B16.1: Cast Iron Pipe Flanges and Flanged Fittings Class 125
- AWWA C508: Swing Check Valves for Waterworks Service, 2" through 24" NPS

Rating:

Valves are rated for 200psi on 12" and smaller, and 150psi on 14" and larger water working pressure. Valves available in ductile iron for high pressure applications. All testing is done in accordance with AWWA C508.

End Configuration: Valves have integrally cast flat face flanges in accordance with ANSI B16.1 Class 125.

Materials:

- All cast iron used conforms to ASTM A126 CLB
- Disc is of ductile iron conforming to ASTM A536 GR65-45-12
- Hinge pins conform to ASTM A276 CR304
- Seat Rings are of Low Zinc Bronze conforming to ASTM B62 or of Stainless Steel conforming to ASTM A276 GR316

Coating: Internal and external coatings are two-component epoxy conforming to AWWA C550.

Design: All valves meet the standards of AWWA C508. All valves utilize a single disc mounted to a clevis hinge which prevents the disc from tipping. The valve disc swings open once the pump starts and allows full flow. When closed the valve offers a tight shut-off. Valve body and cover are of Cast Iron; valve hinge is of Ductile Iron. Disc seating surface is Bronze, Stainless Steel or Buna-N depending on application. Valve seat rings are of Bronze or Stainless Steel.

The valve body has a bolted cover design and flanges are integral to body casting -not wafer style. Valve body and disc are designed in such a way as to minimize turbulence. Spring and cushion systems are externally mounted on the side of the body and do not come into contact with main line media.

The hydraulic cylinder and system, mounted on the external side of the valve, shall cushion the valve as the oil travels from the cylinder to the oil reservoir. The system is totally enclosed and separate from the line media. Contamination of the hydraulic system or obstruction of line flow is prevented in this side-mounted system. The discharge head from the pump allows the valve to open raising the outside lever and weight or spring. The disc swings freely to the open position. Upon pump shut down the outside weight or spring assists the disc to close until the roller on tear drop comes in contact with the pad on the hydraulic cylinder. The cushioning actions occur as the oil flows through the system, closure control takes place by adjustment of the control valve (part number 3). The system is completely field adjustable.

Installation: All valves are built for horizontal installation. However, all valves operate equally well in vertical installations. Prior to valve installation Pratt should be notified of vertical mounting position so lever arm and weight can be properly positioned on valve.

Pratt Series 9001 AWWA Swing Check Valve Oil Decelerator with Outside Lever and Weight or Spring

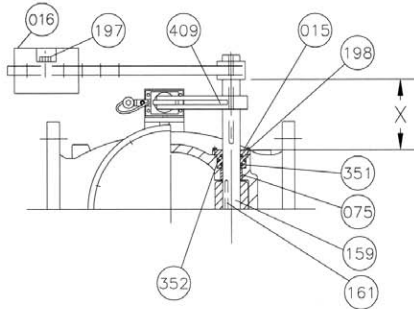
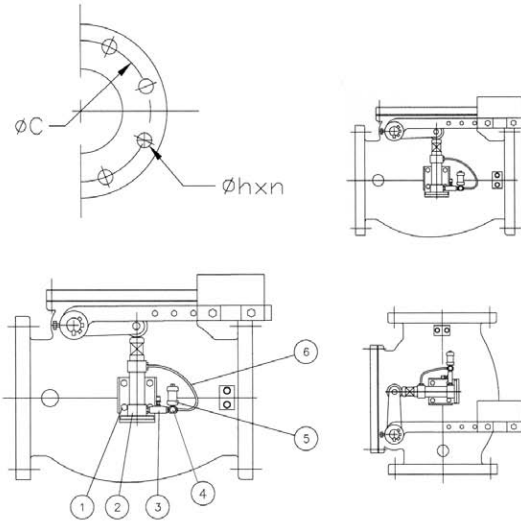
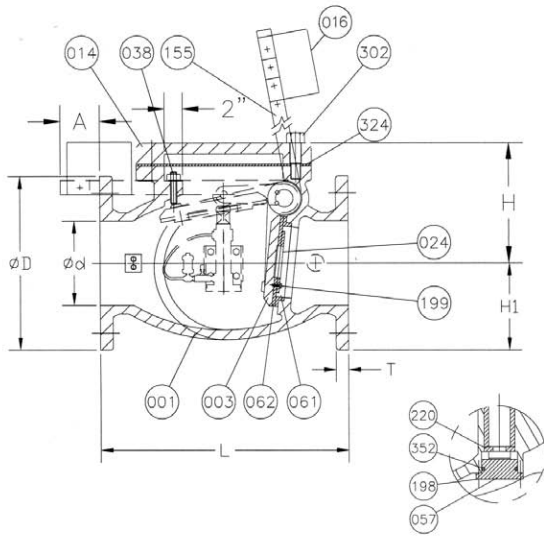

NO.	Parts	Material	ASTM Designation
6	HYDRAULIC HOSE	3000PSI	COMMERCIAL
5	RESERVOIR	PVC	GREY PVC
4	BRASS TEE	BRASS	B124 GR377
3	CONTROL VALVE	BRASS, NEEDLE CHECK	B124 GR377
2	OIL CUSHION	COMMERCIAL HYDRAULIC CYLINDER	NFPA RATED
1	MOUNTING BRACKET	STEEL	A36
409	TEAR DROP	DUCTILE IRON	A536 GR.65-45-12
352	O-RING C	RUBBER (BUNA N)	D2000 BK 707
351	O-RING B	RUBBER (BUNA N)	D2000 BK 707
324	COVER GASKET	RUBBER (BUNA N)	D2000 BK 807
302	COVER BOLT	ZINC COATED STEEL	A307 GRADE B
283	ARM BOLT	ZINC COATED STEEL	A307 GRADE B
220	SNAP RING	STAINLESS STEEL	A276 GRADE 304
199	SEAT HOLDER BOLT	STAINLESS STEEL	A276 GRADE 304
198	END PLATE BOLT	ZINC COATED STEEL	A307 GRADE B
197	WEIGHT BOLT	ZINC COATED STEEL	A307 GRADE B
161	KEY	STAINLESS STEEL	A276 GRADE 304
159	HINGE PIN	STAINLESS STEEL	A276 GRADE 304
155	WEIGHT ARM	DUCTILE IRON	A536 GR.65-45-12
075	BUSHING	BRONZE	B62
062	DISC SEAT RING	RUBBER (BUNA N)	D2000 BK 807
061	BODY SEAT RING	BRONZE	B62
057	END PLATE B	DUCTILE IRON	A536 GR.65-45-12
038	STOPPER	STAINLESS STEEL	A276 GRADE 304
024	SEAT HOLDER	3"-6" CAST IRON	A126 CLASS B
024	SEAT HOLDER	8"+ DUCTILE IRON	A536 GR 65-45-12
016	WEIGHT	CAST IRON	A126 CLASS B
015	END PLATE A	BRONZE	B62
014	COVER	CAST IRON	A126 CLASS B
003	DISC	DUCTILE IRON	A536 GR.65-45-12
001	BODY	CAST IRON	A126 CLASS B

Sizes Od		ANSI B16.1 CL.125						
Inches	L	OD	OC	OH	n	T	H	H1
3	11	7-1/2	6	3/4	4	3/4	6-3/8	3-3/4
4	13	9	7-1/2	3/4	8	15/16	7-3/8	4-1/2
6	16	11	9-1/2	7/8	8	1	9-3/16	5-1/2
8	19-1/2	13-1/2	11-3/4	7/8	8	1-1/8	10-7/8	6-3/4
10	22	16	14-1/4	1	12	1-3/16	13-5/16	8
12	26	19	17	1	12	1-1/4	15-9/16	9-1/2
14	30	21	18-3/4	1-1/8	12	1-3/8	21-1/16	12-1/16
16	30-1/2	23-1/2	21-1/4	1-1/8	16	1-7/16	24	13-5/16
18	33-1/2	25	22-3/4	1-1/4	16	1-9/16	27-9/16	14-5/8
20	40	27-1/2	25	1-1/4	20	1-11/16	31-5/16	15-3/8
24	46	32	29-1/2	1-3/8	20	1-7/8	35-1/4	17-7/8
30	60	38-3/4	36	1-3/8	28	2-1/8	36	23-1/16
36	63	46	42-3/4	1-5/8	32	2-3/8	41-15/16	27-11/16
42	70	53	49-1/2	1-5/8	36	2-5/8	46-3/4	32-1/8
48	76	59-1/2	56	1-5/8	44	2-3/4	53-1/8	35-1/2

Dimensions for larger sizes available upon request.

* For reference ONLY. Contact Pratt for detailed sales drawings.

Pratt Series 9001 AWWA Swing Check Valve Three Stage Oil Cushion with Outside Lever and Weight or Spring

Features:

- Clear waterway
- Enlarged stainless steel hinge pin
- Flanges conform to ANSI B16.1 Class 125
- Lever and weight may be installed on either side
- Valves may be installed in vertical line with flow up
- Body and disc seat rings are field replaceable
- Disc seat standard with Buna-N insert for bubble tight shut off
- Meets AWWA standards of dimensional standards of large pin cushion products
- 100% oil controlled system with adjustable speed control valve timing valve
- Totally enclosed oil cushion system with stainless steel hardware
- 8 mils NSF 61 epoxy in and out

Sizes: 3" - 72"

Styles: Bronze to Bronze, Bronze to Buna-N, Stainless Steel to Buna-N

Uses: Water, Sludge, Sewer Service

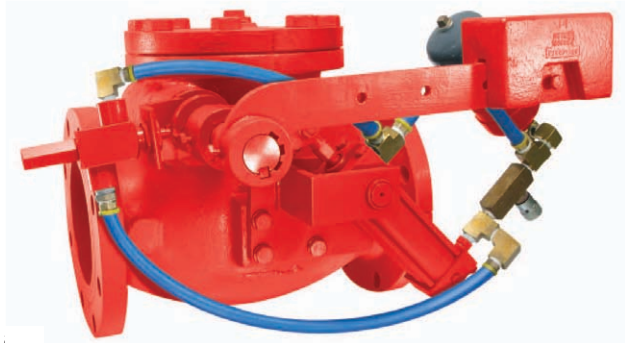

Specification for Series 9001 with 3-Stage Oil Cushion

General: Swing check valves are of self-contained, free-swinging disc style, allowing a clear waterway. Valve disc swings freely open and is keyed to valve hinge pin without the use of pins. Valves conform to all standards set forth in AWWA C508, Latest Edition. Valve hinge pins are Stainless Steel and conform to the industry standards set forth for cushion valves. Manufacturer should have a minimum of ten years experience supplying air and oil cushion AWWA C508 valves.

Referenced Standards:

- ANSI B16.1: Cast Iron Pipe Flanges and Flanged Fittings Class 125
- AWWA C508: Swing Check Valves for Waterworks Service, 2" through 24" NPS

Rating: Valves are rated for 200psi on 12" and smaller, and 150psi on 14" and larger water working pressure. Valves available in ductile iron for high pressure applications. All testing is done in accordance with AWWA C508.

End Configuration: Valves have integrally cast flat face flanges in accordance with ANSI B16.1 Class 125.

Materials:

- All cast iron used conforms to ASTM A126 CLB
- Disc is of ductile iron conforming to ASTM A536 GR65-45-12
- Hinge Pins conform to ASTM A276 GR316
- Seat Rings are of Stainless Steel conforming to ASTM A276 GR316

Coating: Internal and external coatings are two-component epoxy conforming to AWWA C550.

Design: All valves meet the standards of AWWA C508. All valves utilize a single disc mounted to a clevis hinge which prevents the disc from tipping. The valve disc swings open once the pump starts and allows for full flow. When closed the valve offers a tight shut-off. Valve body and cover are of Cast Iron; valve hinge is of Ductile Iron. Disc seating surface is Buna-N with seat holder of Stainless Steel. Valve seat rings are of Stainless Steel ASTM A276 GR316. Cover fasteners shall be Stainless Steel.

The valve body has a bolted cover design and flanges are integral to body casting -not wafer style. Valve body and disc are designed in such a way as to minimize turbulence. Spring and cushion systems are externally mounted on the side of the body and do not come into contact with main line media.

The three stage oil cushion system is totally enclosed, providing slow open and controlled closing to prevent surge and water hammer. Stage one shall be controlled by a timing valve, stage two by flow control valve and stage three by an internal cushion adjustment of the cylinder. Each stage is independently field adjustable in this totally enclosed system. The timing valve is plunger activated that makes contact with the cam on the hinge pin. Adjustment of the cam increases or reduces the closure speed of the swing check valve. The cushioning actions occur as the oil flows through the system.

Installations: All valves are built for horizontal installation. However, all valves operate equally well in vertical installations. Prior to valve installation Pratt should be notified of vertical mounting position so lever arm and weight can be properly positioned on valve.

Pratt Series 9001 AWWA Swing Check Valve Three Stage Oil Cushion with Outside Lever and Weight or Spring

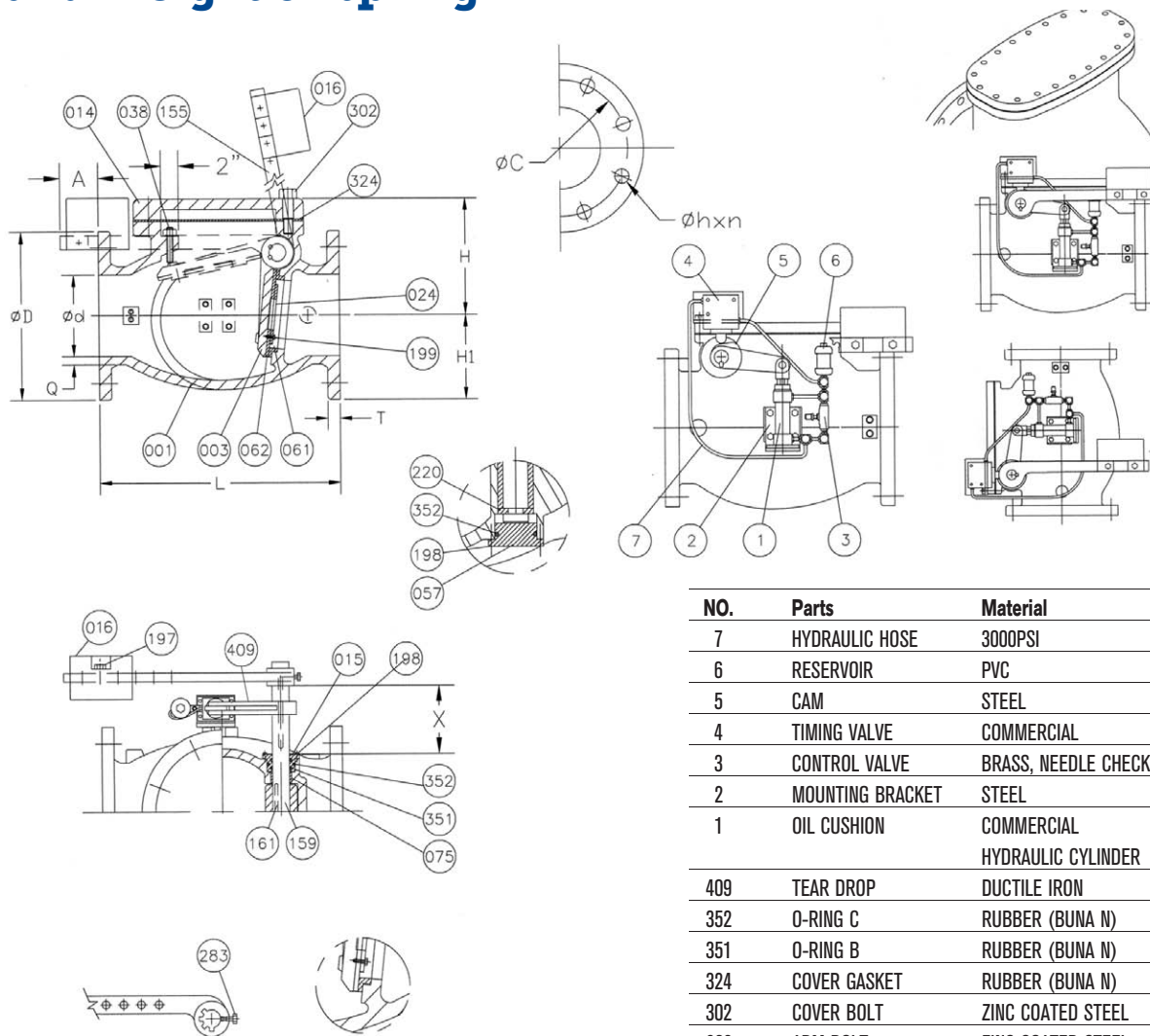

Size Od	ANSI B16.1 CL.125							
Inches	L	OD	OC	OH	n	T	H	H1
3	11	7-1/2	6	3/4	4	3/4	6-3/8	3-3/4
4	13	9	7-1/2	3/4	8	15/16	7-3/8	4-1/2
6	16	11	9-1/2	7/8	8	1	9-3/16	5-1/2
8	19-1/2	13-1/2	11-3/4	7/8	8	1-1/8	10-7/8	6-3/4
10	22	16	14-1/4	1	12	1-3/16	13-5/16	8
12	26	19	17	1	12	1-1/4	15-9/16	9-1/2
14	30	21	18-3/4	1-1/8	12	1-3/8	21-1/16	12-1/16
16	30-1/2	23-1/2	21-1/4	1-1/8	16	1-7/16	24	13-5/16
18	33-1/2	25	22-3/4	1-1/4	16	1-9/16	27-9/16	14-5/8
20	40	27-1/2	25	1-1/4	20	1-11/16	31-5/16	15-3/8
24	46	32	29-1/2	1-3/8	20	1-7/8	35-1/4	17-7/8
30	60	38-3/4	36	1-3/8	28	2-1/8	36	23-1/16
36	63	46	42-3/4	1-5/8	32	2-3/8	41-15/16	27-11/16
42	70	53	49-1/2	1-5/8	36	2-5/8	46-3/4	32-1/8
48	76	59-1/2	56	1-5/8	44	2-3/4	53-1/8	35-1/2

Dimensions for larger sizes available upon request.

NO.	Parts	Material	ASTM Designation
7	HYDRAULIC HOSE	3000PSI	COMMERCIAL
6	RESERVOIR	PVC	GREY PVC
5	CAM	STEEL	A36
4	TIMING VALVE	COMMERCIAL	FORGED STEEL
3	CONTROL VALVE	BRASS, NEEDLE CHECK	B124 GR377
2	MOUNTING BRACKET	STEEL	A36
1	OIL CUSHION	COMMERCIAL HYDRAULIC CYLINDER	NFPA RATED
409	TEAR DROP	DUCTILE IRON	A536 GR.65-45-12
352	O-RING C	RUBBER (BUNA N)	D2000 BK 707
351	O-RING B	RUBBER (BUNA N)	D2000 BK 707
324	COVER GASKET	RUBBER (BUNA N)	D2000 BK 807
302	COVER BOLT	ZINC COATED STEEL	A307 GRADE B
283	ARM BOLT	ZINC COATED STEEL	A307 GRADE B
220	SNAP RING	STAINLESS STEEL	A276 GRADE 304
199	SEAT HOLDER BOLT	STAINLESS STEEL	A276 GRADE 304
198	END PLATE BOLT	ZINC COATED STEEL	A307 GRADE B
197	WEIGHT BOLT	ZINC COATED STEEL	A307 GRADE B
161	KEY	STAINLESS STEEL	A276 GRADE 304
159	HINGE PIN	STAINLESS STEEL	A276 GRADE 304
155	WEIGHT ARM	DUCTILE IRON	A536 GR.65-45-12
075	BUSHING	BRONZE	B62
062	DISC SEAT RING	RUBBER (BUNA N)	D2000 BK 807
061	BODY SEAT RING	BRONZE	B62
057	END PLATE B	DUCTILE IRON	A536 GR.65-45-12
038	STOPPER	STAINLESS STEEL	A276 GRADE 304
024	SEAT HOLDER	3"-6" CAST IRON	A126 CLASS B
024	SEAT HOLDER	8"+ DUCTILE IRON	A536 GR 65-45-12
016	WEIGHT	CAST IRON	A126 CLASS B
015	END PLATE A	BRONZE	B62
014	COVER	CAST IRON	A126 CLASS B
003	DISC	DUCTILE IRON	A536 GR.65-45-12
001	BODY	CAST IRON	A126 CLASS B

* For reference ONLY. Contact Pratt for detailed sales drawings.

Pratt Series 8501 Ductile Iron AWWA Swing Check Valves Air Cushion with Outside Lever and Weight or Spring

Features:

- Full waterway
- Ductile iron body, cover and disc hinge arm construction
- Stainless steel hinge pin
- Flanges conform to ANSI B16.1 Class 125 (250# flange available)
- Lever and weight may be installed on either side
- Valves may be installed in vertical line with flow up
- Disc seat standard with Buna-N insert for bubble tight shut off
- Body and disc seat rings are field replaceable
- Meets AWWA standards
- Totally enclosed bronze air cushion with stainless steel hardware
- For cushioning in low velocity applications (8-10 feet/second)
- Adjustable speed control
- 8 mils NSF 61 epoxy in and out

Sizes: 3" - 24"

Styles: Stainless Steel to Buna-N standard

Uses: Water, Sludge, Sewer Service

Test Pressures:

Seat*	Shell
350psi	700psi

*rated working pressure



Specification:

General: Swing check valves are of self-contained, free-swinging disc style, allowing a full waterway. Valve disc swings freely open and is keyed to valve hinge pin without use of pins. Valves conform to all standards set forth in AWWA C508, Latest Edition. Valve hinge pins are Stainless Steel. Manufacturer should have minimum of 10 years experience supplying AWWA C508 valves

Referenced Standards:

- ANSI B16.1: Cast Iron Pipe Flanges and Flanged Fittings Class 125
- AWWA C508: Swing Check Valves for Waterworks Service, 2" through 24"

Rating: Valves are rated for 350psi water working pressure. All testing is done in accordance with AWWA C508.

End Configuration: Valves have integrally cast flat face flanges in accordance with ANSI B16.1 Class 125.

Materials:

- All ductile iron, which includes Hinge, Disc, Body and Cover conforms to ASTM GR-65-45-12
- Hinge Pins conform to ASTM A276 GR316
- Seat Rings are Stainless Steel conforming to ASTM A276 GR316

Coatings: Internal and external coatings are two-component epoxy conforming to AWWA C550.

Design: All valves meet the standards of AWWA C508. All valves utilize a single disc mounted to a clevis hinge which prevents the disc from tipping. The valve disc swings open once the pump starts and allows for full flow. When closed the valve offers a tight shut-off. Valve body, cover and valve hinge are of Ductile Iron. Disc seating surface is Buna-N. Valve seat rings are of Stainless Steel.

The valve body has a bolted cover design and flanges are integral to body casting -not wafer style. Valve body and disc are designed in such a way as to minimize turbulence. Spring and Cushion systems are externally mounted on the side of the body and do not come in contact with main line media.

Cushion systems are one piece all bronze construction with integral pad mounted directly to the body with stainless steel fasteners. Air cushion shall consist of bronze and stainless steel components, be adjustable by means of a flow control valve and piston sleeve. Air cushion shall be totally enclosed with a metal end cap with an o-ring.

Installation: All valves are built for horizontal installation. However, all valves operate equally well in vertical installations. Prior to valve installation Pratt should be notified of vertical mounting position so lever arm and weight can be properly positioned on valve.

Pratt Series 8501 Ductile Iron AWWA Swing Check Valves Air Cushion with Outside Lever and Weight or Spring

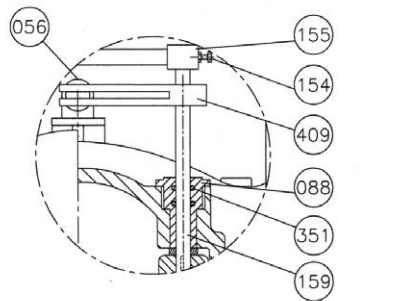
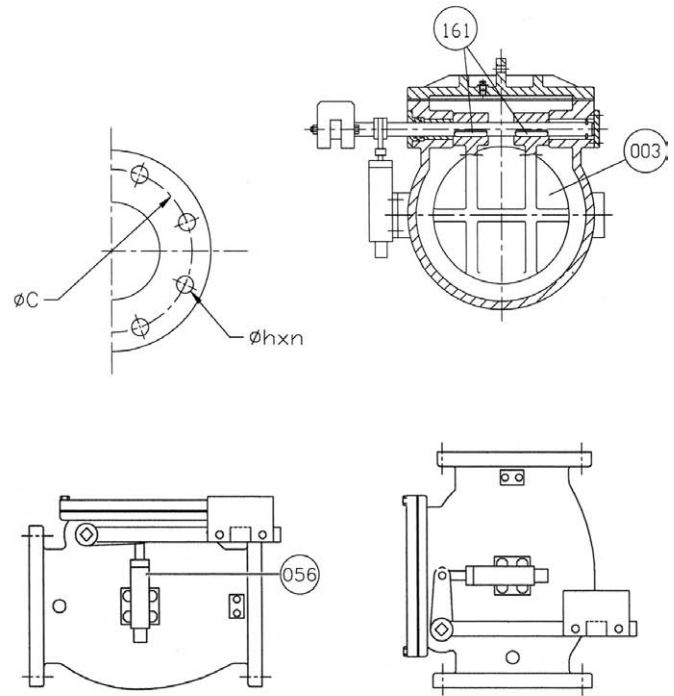
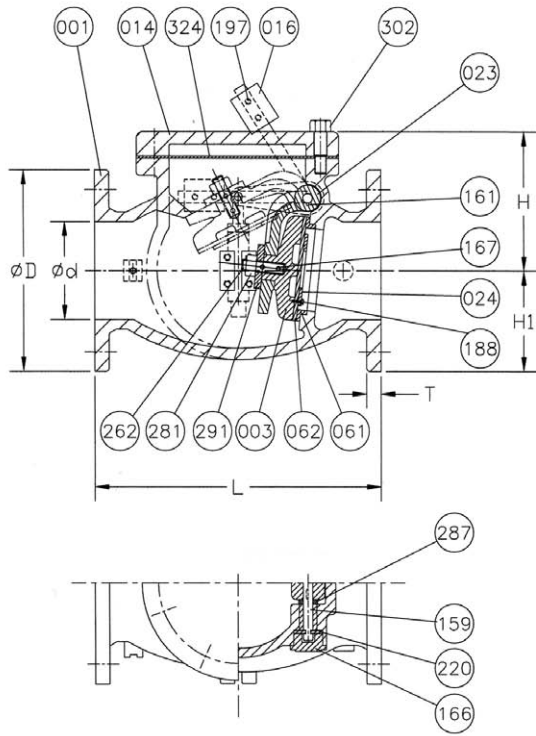

Size Od	ANSI B16.1 CL.125								
	Inches	L	OD	OC	OH	n	T	H	H1
3	9-1/2	7-1/2	6	3/4	4	3/4	6-1/16	3-3/4	
4	11-1/2	9	7-1/2	3/4	8	15/16	6-5/8	4-1/2	
6	14	11	9-1/2	7/8	8	1	8-1/2	5-1/2	
8	19-1/2	13-1/2	11-3/4	7/8	8	1-1/8	9-15/16	6-3/4	
10	24-1/2	16	14-1/4	1	12	1-3/16	11-3/16	8	
12	27-1/2	19	17	1	12	1-1/4	13-9/16	9-1/2	
14	31	21	18-3/4	1-1/8	12	1-3/8	19-5/16	12-1/16	
16	36	23-1/2	21-1/4	1-1/8	16	1-7/16	21-1/2	13-5/16	
18	40	25	22-3/4	1-1/4	16	1-9/16	25	14-5/8	
20	40	27-1/2	25	1-1/4	20	1-11/16	27-9/16	15-3/8	
24	48	32	29-1/2	1-3/8	20	1-7/8	32-11/16	17-7/8	

Dimensions for larger sizes available upon request.

NO.	Parts	Material	ASTM Designation
056	AIR CUSHION	BRONZE	B62
409	TEAR DROP	DUCTILE IRON	A536 GR.65-45-12
351	O-RING	RUBBER (BUNA N)	D2000 BK 707
324	COVER GASKET	RUBBER (BUNA N)	D2000 BK 807
302	COVER BOLT	ZINC COATED STEEL	A307 GRADE B
291	WASHER	BRASS	B21
287	SPACER	BRASS	B21
281	DISC NUT	BRASS	B21
262	DISC STUD	BRASS	B21
220	SNAP RING	STAINLESS STEEL	-
197	WEIGHT BOLT W/NUT	ZINC COATED STEEL	A307 GRADE B
188	DISC SEAT BOLT	STAINLESS STEEL	A276 GRADE 304
167	ROLL PIN	STAINLESS STEEL	A276 GRADE 304
166	PLUG	MALLEABLE IRON	A47
161	KEY	STAINLESS STEEL	A27 GRADE 304
159	HINGE PIN	STAINLESS STEEL	A276 GRADE 316
155	LEVER	DUCTILE IRON	A536 GR.65-45-12
154	BOLT W/NUT	ZINC COATED STEEL	A307 GRADE B
088	SEAT NUT	BRASS	B21
062	DISC SEAT RING	RUBBER (BUNA N)	D2000 BK 807
061	BODY SEAT RING	STAINLESS STEEL	A276 GRADE 316
024	SEAT HOLDER	DUCTILE IRON	A536 GR.65-45-12
023	HINGE	DUCTILE IRON	A536 GR.65-45-12
016	WEIGHT	CAST IRON	A126 CLASS B
014	COVER	DUCTILE IRON	A536 GR.65-45-12
003	DISC	DUCTILE IRON	A536 GR.65-45-12
001	BODY	DUCTILE IRON	A536 GR.65-45-12

* For reference ONLY. Contact Pratt for detailed sales drawings.

Notes

Notes

PRATT PRODUCT GUIDE

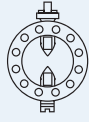

**Model
2FI**

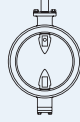

**Monoflange
MKII**

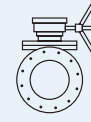

**Plug
Valve**

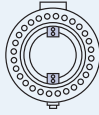

**Triton®
XR70**

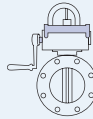

**Indicating Butterfly Valve
UL & FM approved**

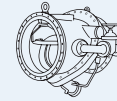

**Tilting Disc
Check Valve**

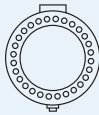

**Triton®
XL**



**N-Stamp Nuclear
Butterfly Valve**

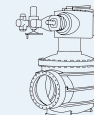

**Cone
Valve**

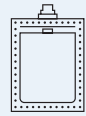

Rectangular

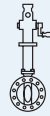

**PIVA Post Indicating Valve Assembly
UL & FM approved**

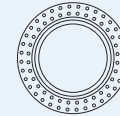

**Sleeve
Valve**

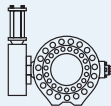

**Rubber Seated
Ball Valve**

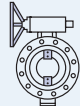

**Triton®
HP250**

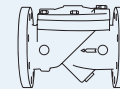

**Check
Valve**



**Groundhog®
Valve**

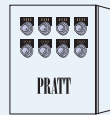

**Control
Systems**

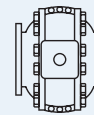

**Metal Seated
Ball Valve**

PRATT



**Manual Valve
Actuators**

Henry Pratt Company

401 South Highland Avenue
Aurora, Illinois 60506-5563
United States
630-844-4000
Fax 630-844-4160
www.henrypratt.com
ISO 9001: 2000 Certified