

# PRATT

Henry Pratt Company

## **Triton XR-70 Butterfly Valve**

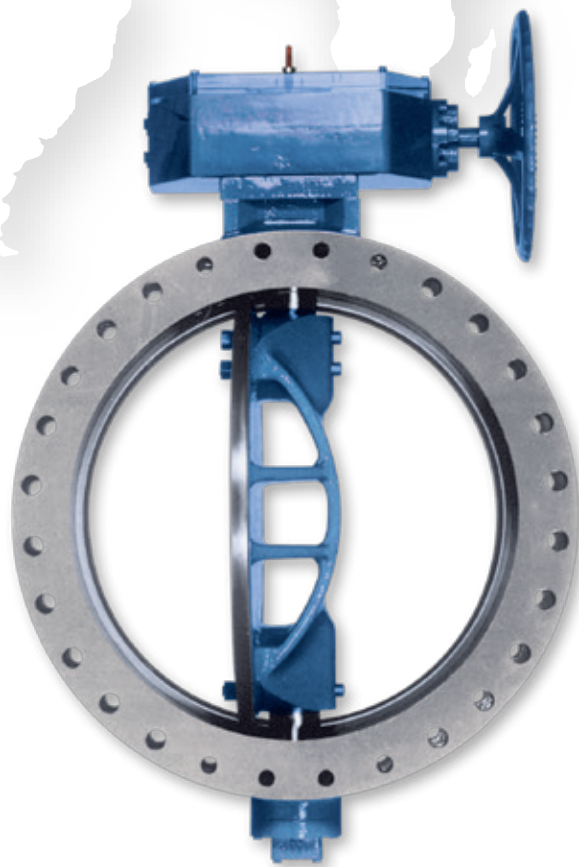

**Engineering Creative Solutions  
for Fluid Systems Since 1901**

## A Tradition of Excellence

With the development of the first rubber seated butterfly valve more than 70 years ago, the Henry Pratt Company became a trusted name in the flow control industry, setting the standard for product quality and customer service. Today Pratt provides the following range of superior products to the water, wastewater and power generation industries.

**Butterfly Valves:** from 3" to 162"

**Rectangular Valves:** 1' x 1' to 14' x 16'

### Ball Valves –

**Rubber Seated:** from 4" to 60"

**Metal Seated:** from 6" to 48"

**Plug Valves:** from 1/2" to 72", 100% port available up to 48", 3 ways

**Air Valves for Water and Wastewater:** from 1/2" to 20"

## Hydraulic Control Systems

### Valve Controls

### Energy Dissipating Valves and Fixed Energy Dissipaters

### Cone Valves

### Check Valves

### Plunger Valves

## A Commitment to Meeting The Customers' Needs

Henry Pratt valves represent a long-term commitment to both the customer and to a tradition of product excellence. This commitment is evident in the number of innovations we have brought to the industries we serve. In fact, the Henry Pratt Company was the first to introduce many of the flow control products in use today, including the first rubber seated butterfly valve, one of the first nuclear N-Stamp valves, and the bonded seat butterfly valve.

## Innovative Products For Unique Applications

Though many of the standard valves we produce are used in water filtration and distribution applications, Pratt has built a reputation on the ability to develop specialized products that help customers to meet their individual operational challenges.

## Creative Engineering for Fluid Systems

Pratt's ability to provide practical solutions to complex issues is demonstrated by the following case histories.

### Earthquake Proof Valves

Pratt designed and manufactured hydraulically actuated valves for a water storage application so that the valves would automatically operate in the event of earthquakes. This led to the development of a valve that will withstand acceleration forces of up to 6gs.

### Custom Actuation/Isolation Valves

Pratt has designed and manufactured nuclear quality quarter-turn valves and parts since the first nuclear-powered generating plants were built. Our custom valves are able to close in a millisecond, using specially designed Pratt electro-pneumatic actuators.

### Valves Designed for Harsh Environments

Pratt designed and manufactured a 144" diameter butterfly valve for the emergency cooling system at a jet engine test facility. The valve was designed to supply water to help dissipate the tremendous heat generated by the engines during testing.



**PRATT**  
Henry Pratt Company

**Through experience, commitment and creative engineering, Pratt is uniquely suited to provide superior products for our customers' special needs. For more information, contact our corporate headquarters in Aurora, Illinois.**

## Table of Contents

### Pratt / Triton XR-70 Butterfly Valve

Scope of Line.....	2
Features & Benefits.....	3
Design Details.....	4-5
E-Lok Seat Design.....	6
Flow Through Design.....	6
Coatings and Rubber Linings.....	7
Water Flow Characteristics.....	8-9
Valve End Types and Dimensions: Mechanical Joint End & Flanged End.....	10
Suggested Specifications for Butterfly Valves 24" and larger Cast Construction.....	11
Actuation.....	12

## Scope of Line: Triton XR-70 Butterfly Valve



Pratt Triton XR-70

**Sizes:** 24 through 144 inches

**Standard Body Styles:**

- Flange x flange ends
- Mechanical Joint ends (24"-48")
- Flange and Mechanical Joint ends (24", 30", 36")

**Standards:**

- Conforms to AWWA C504 requirements

**Pressure Class:**

- AWWA pressure classes 75B (54"-144") and 150B

**Seat:** Rubber seat-in-body

**Actuation Options:**

- Pratt MDT manual actuator with AWWA nut, handwheel or chainwheel
- Worm gear actuators
- Pratt Dura-Cyl hydraulic or pneumatic cylinder

**Accessories/Options:**

Anti-cavitation device, bonnets, floorstands, lantern glands, shaft locking devices, external epoxy injection port, snubbers, expansion joints, rubber lining

*Consult factory for accessory details.*

**Optional Body Styles:**

- **Victaulic Ends**
- **Concrete Pipe Ends**

*Consult factory for lead times.*

## Features and Benefits: Triton XR-70 Butterfly Valve

Feature	Benefit
<b>E-Lok seat in design</b>	– No hardware to loosen. Precision rubber seat installation and uniform interference provide long seat life. Foolproof adjustment and/or replacement (in most cases without removing the valve from the line)
<b>Rubber seat located in body</b>	– Reduces performance problems related to corrosive buildup in valve body and pipeline.
<b>Optional external injection port</b>	– E-Lok seat can be adjusted and/or repaired in the field without dewatering the pipeline
<b>Seat material also available in EPDM</b>	– Can accommodate temperatures up to 250 degrees F
<b>Valve cycle tested per AWWA C504 requirements</b>	– Proven reliability over the life of the valve
<b>Flow through disc on 30 inch and larger</b>	– More strength, less weight, greater free flow area. Higher $C_v$ : lower head loss results in energy savings for customer's system
<b>Nonmetallic bearings</b>	– Prevents galvanic corrosion and provides lower coefficient of friction
<b>V-type shaft packing</b>	– Self-adjusting, lasts the life of the valve
<b>Through disc pinning</b>	– Provides a tight disc-to-shaft pin connection, greatly reducing the possibility of loosening through vibration

Specifications for Materials of Construction
<b>Body Material:</b> Cast Iron (24"-48") – ASTM A126, Class B Ductile Iron (54" & Larger) – ASTM A536, Grade 65-45-12
<b>Disc Material:</b> Ductile Iron – ASTM A536, Grade 65-45-12
<b>Disc Edge:</b> Stainless Steel – ASTM A-240 Type 316
<b>Shaft Material:</b> 304 Stainless Steel – ASTM A276 Type 304
<b>Bearing Material:</b> TLFB – Teflon lined, Fiberglass backed

# Design Details: Triton XR-70 Butterfly Valve

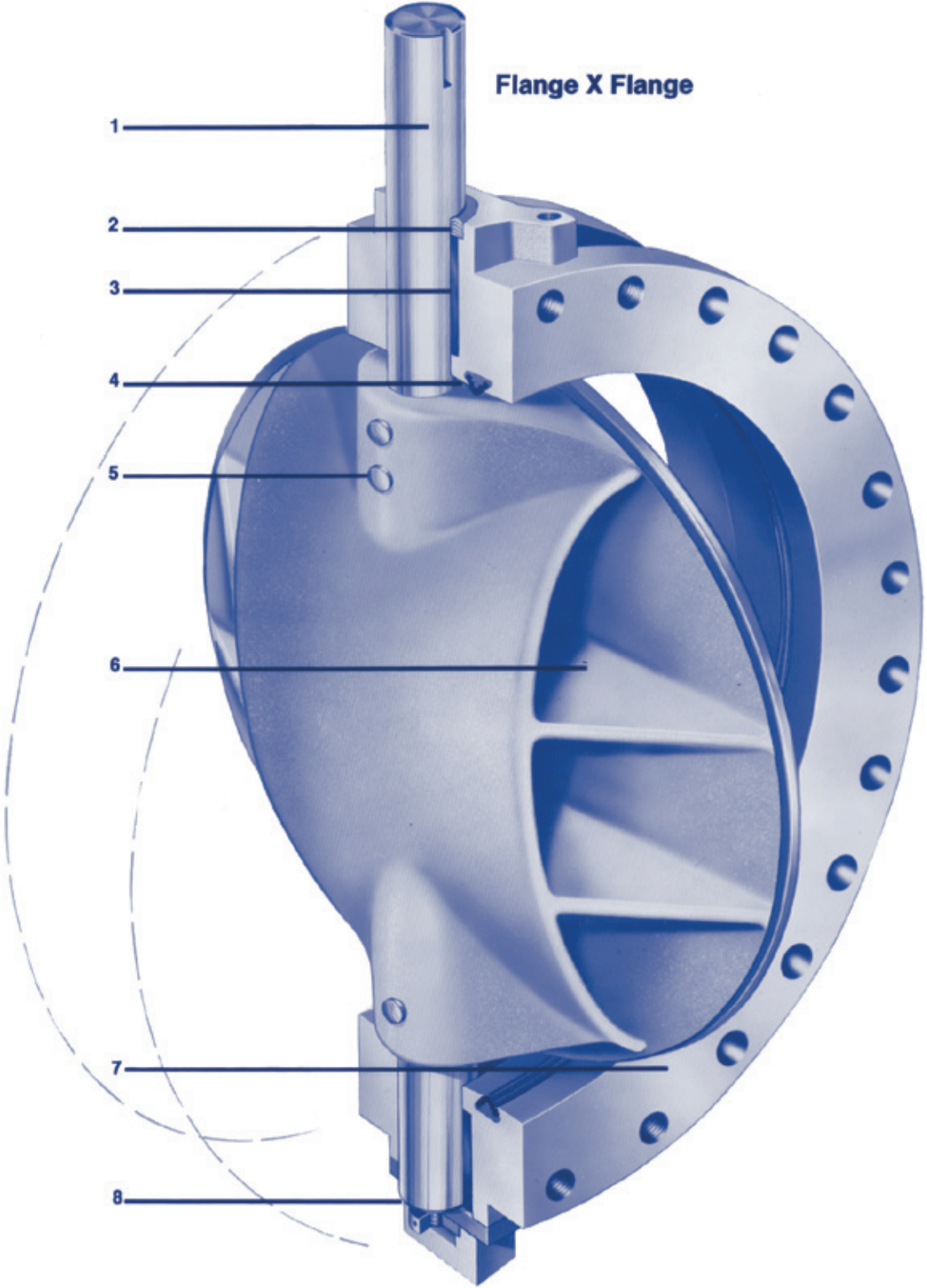

# Design Details: Triton XR-70 Butterfly Valve

## 1) Corrosion Resistant Shafts

To prevent corrosion of a vital structural component, shafts are constructed of centerless ground ASTM A276 type 304. This material is superior to carbon steel or similar materials that afford little protection against the harmful effects of corrosion. Pratt's standard line consists of a two-piece, stub-type shaft keyed for the actuator connection.

## 2) Packing and Packing Gland Assemblies

Packing is self adjusting "V" type. The packing gland or shaft seal is utilized only in the top trunnion of the valve body where the shaft protrudes for actuator connection. The packing assembly incorporates a nylon packing retainer accompanied by several rings of packing. Other available packing gland arrangements include water seals (lantern glands) for positive and negative pressures, and reverse "V" type for vacuum applications. Where access to packing is required, open-type bonnets can be provided. When this option is specified, "V" type packing is held in place with a bronze retaining gland which is fastened to the valve trunnion with plated steel cap screws.

## 3) Bearings

Self-lubricating, sleeve-type bearings are used in both trunnions of the valve body. Bearings support the shaft and provide minimum friction during shaft rotation. Bearing material is Teflon-lined with a special fiberglass backing. This type of bearing offers electrical insulating qualities between the disc/shaft assembly and the valve body, thereby diminishing the effects of galvanic corrosion. In addition, its reduced coefficient of friction requires far less torque than the metallic bearing materials.

## 4) Rubber Seat

The multi-ridge surface of Pratt's E-Lok seat seals a full 360° against a stainless steel spherical disc edge. Because of the laterally spaced grooves, rubber stress is substantially reduced, resulting in less sealing torque. The grooved seat design, coupled with the wide spherically shaped seating edge of the disc, also allows greater disc closure tolerance. Regardless of valve size, angular misposition of the disc can be 1° off center without leakage. The seat is mechanically retained by a unique epoxy injection process which moves the seat against the disc to conform to the exact radius of the disc with uniform contact pressure. It is fully adjustable by local epoxy injection and can be replaced in the field. As an option, valves may be purchased with an external injection port which allows seat adjustment and repair to be performed without removing the valve or dewatering the pipeline. For additional information regarding the E-Lok seat, refer to the "E-Lok Seat Design" section of this brochure.

## 5) Shaft Connection

Disc-to-shaft connection is accomplished by conservatively sized stainless steel or monel taper pins, threaded at one end and secured with lockwashers and nuts. On 24 inch valves, stainless steel dowel pins are used. Pratt's through-pin design provides the tightest possible connection between the shaft and disc.

## 6) Valve Disc

Pratt valve discs are constructed of the highest strength-to-weight ratio materials available. On our 24 inch valve, the arch side of the disc is closed and the flat side is open, forming a slightly concave surface. On valves 30 inches and greater, a flow through disc design is employed to minimize line turbulence and lower head loss. The greater free flow area provides less pressure drop in the full-open position than other disc shapes. For additional information regarding Pratt's flow through disc design, refer to "Flow through Design" section of this brochure.

## 7) Valve Body

The bodies of the XR-70 are constructed of heavy cast iron ASTM A126. On flange end bodies, flange drilling is provided in accordance with ANSI B16.1 for cast iron flanges through 72 inches. Larger sizes where applicable per AWWA C207.

## 8) Thrust Bearing Assembly

The two-way thrust bearing is preset at the factory. On valves 30 inches and larger, the thrust bearing assembly consists of a stainless steel or monel stud fastened to the bottom of the valve shaft. The stud extends beyond the bottom cover. The thrust collar is threaded to the stud and pinned. On the 24 inch valve, the thrust collar is pinned to the shaft and fitted with bronze spacers. The bottom cover cap is then bolted to the bottom cover and retains the thrust collar which, in turn, retains the position of the disc assembly. The cavity containing the thrust collar is packed with grease providing lifetime lubrication of the thrust bearing assembly. The cap is fully gasketed to prevent leakage.

## Valve End Connection Options

A wide range of valve end connection options for the Pratt Triton XR-70 are available. See "Valve End Types and Dimensions" section for details.

## Actuation Options

See "Actuation" section for Pratt actuators or refer to Pratt's Actuator brochure for the many actuation options available for the Triton XR-70.

# E-Lok Seat Design

## Years of Reliable Service

The Triton XR-70 utilizes the unique and patented\* E-Lok seat-in-body design. With years of reliable performance, the E-Lok's seat retention system still remains one of the most innovative concepts in butterfly valve seat design. This design is often imitated without the superior results that only Pratt experience can deliver.

## How the E-Lok Seat Provides Bubble Tight Closure

The rubber seat, which is mounted in the valve body, seals a full 360° against a stainless steel disc edge with low torque and high tolerance to seating angle. The ridges molded into the seat surface greatly reduce the possibility of the seat being over compressed and minimizes compression set of rubber. In manufacturing, a two part epoxy compound is injected into a channel behind the rubber seat with the disc in the closed position. This ensures equal interference around the complete circumference of the disc/seat contact area. The epoxy hardens, bonding neither to the metal seat channel nor to the rubber seat, yet mechanically retains the seat in the body. Since the seat is installed and remains in a "relaxed" state, the possibility of damaging the seat is greatly reduced as compared to a seat that is "stressed" when bolted on to a body or disc as in other designs.

During injection, the seat is moved against the disc as the epoxy fills the cavity to provide uniform disc-to-seat interference around the entire seating surface. The result is the bubble tight closure. This system eliminates conventional seat retention hardware that can loosen and corrode, potentially damaging pumps and other costly auxiliary equipment.

## Simple Seat Adjustment

Another significant feature of the E-Lok seat is that it can be easily adjusted or replaced in the field while the valve is installed in the line. Adjustment is achieved by local injection of epoxy directly through the seat material into the channel behind the seat. The epoxy travels the circumference of the valve body channel until it finds the void and moves the seat material outward toward the disc edge, bringing the valve back into bubble tight condition. If the valve was supplied with the optional\*\* external injection

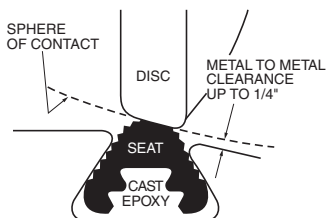

port, the seat can be adjusted from the outside of the valve without dewatering the pipeline. The injection process can be achieved by utilizing simple tools and an inexpensive, disposable seat injection kit.

## Easy Seat Replacement

In the unlikely event that seat replacement is required, it can be performed on valves 30 inches and larger without removing the valve from the pipeline (as long as a technician can access inside the valve), on all sizes without removing the shaft and/or disc. The original rubber seat and hardened epoxy compound used to retain the seat can be removed from the valve with ordinary hand tools. A replacement seat can then be installed, returning the valve to its original bubble tight condition.

## Flow Through Design

The Triton disc design distributes material where it is needed to resist loads, achieving more strength at less weight than any other disc design currently on the market. The flow through disc has a greater free flow area than conventional lens-shaped or offset disc designs, resulting in lower pumping costs.



\* U.S. Patent Nos. 3,304,050 and 3,418,411

\*\* U.S. Patent No. 5,538,029



# Coatings and Rubber Linings

## Withstanding Harsh Conditions and the Test of Time

In many industrial facilities, valves are regularly subjected to harsh conditions, including recirculating water loops where corrosiveness increases each time the water passes through the system, and cooling water systems which utilize brackish water or salt water as a medium. This is especially true at fossil and nuclear power generating plants, which frequently use sea water as their main cooling water resource.

To combat the damaging effects of these harsh conditions, Pratt utilizes epoxy coatings and rubber linings in conjunction with superior design features to help ensure that the Triton XR-70 butterfly valves will withstand the test of time.

The unique construction of the Pratt Triton rubber seated butterfly valve makes both epoxy coatings and rubber linings much more effective than other butterfly valve designs. Since all surfaces of the Triton disc are exposed, there is no possibility for corrosion to start in hidden, unprotected areas like the inside of a hollow, lens-shaped offset disc. Since there is no seat retention hardware, coating and/or lining breakdown in this area is also eliminated.

In applications involving salt water and/or entrained solids which can cause erosion, the superiority of rubber lining on the valve disc has been clearly demonstrated by Pratt butterfly valves placed in service decades ago that are still providing bubble tight closure today. Both epoxy coating and rubber lining have also successfully protected the valve bodies in these corrosive service conditions as illustrated by Pratt's long track record of quality and reliability at industrial facilities and power plants around the world.

Other rubber lining features include Pratt's shaft-bearing being thoroughly protected by rubber shaft seals to maintain bearing performance throughout the life of the valve. Also, the shaft bore in disc is sealed with a rubber seal. The juncture of the rubber liner to the rubber seat is also protected by a sealant applied under pressure.

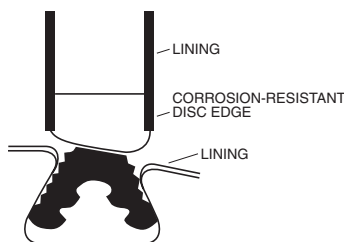

Complete coverage of corrosion susceptible wetted surfaces is demonstrated in these drawings. Body lining in conjunction with the seat creates a water barrier and protects against corrosion.

## Rubber Linings

Pratt lines corrosion-susceptible surfaces with a  $\frac{3}{16}$ -inch thick rubber of 60 Shore A durometer. The surfaces are prepared and blasted to a near- white metal finish. The linings are applied by the "hand-lay-up-method" (similar to tank lining techniques) and then cured in an open steam autoclave using 40 to 50 psig steam pressure. Following application and curing, the linings are visually inspected for air bubbles and checked at 7,000 volts with a positive control high-voltage spark tester.

## Epoxy Coatings

Pratt has an extensive coating facility which applies and cures coatings in a controlled environment. Prior to application of the epoxy, valves are sandblasted and thoroughly cleaned to ensure a proper bond. The interior and external surfaces of each valve are coated with a Polyamide-cured, rust inhibiting epoxy, NSF approved. A magnetic dry film thickness gauge is used to confirm that the coating thickness matches the project/order specification requirements. Electronic testing for pin holes (holidays) is available. Contact Pratt for options and pricing..

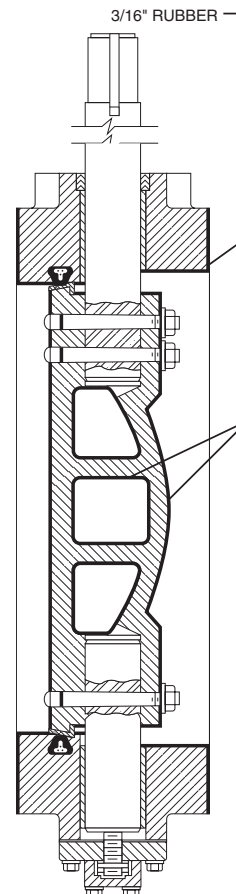

# Water Flow Characteristics

## Proven Performance

During its product development phase, the Triton butterfly valve was tested to ensure that it met our own rigorous standards for flow capacity. The Triton butterfly valve consistently produced high  $C_v$  values which translates to lower flow resistance, in turn, lowering system operating costs to the user over the life of the valve.

### Full Open $C_v$ Valves Triton XR-70 Valves Class 150B

10 Bar		
Size	Flat	Arch
24	25380	26378
30	39657	41216
36	59351	62447
42	85899	89170
48	112195	116466
54	141808	146563
60	172343	176486
66	208535	213548
72	248174	254139
78	291260	298261
84	337793	345912
90	387772	397093
96	441199	451803
102	498072	510043
108	558392	571813
114	622159	637113
120	689373	705942
132	834171	854190
144	992697	1016557

# TRITON XR-70, 24" - 72" (Pipe Inlet-Pipe Outlet) Pressure Class 150A, 150B

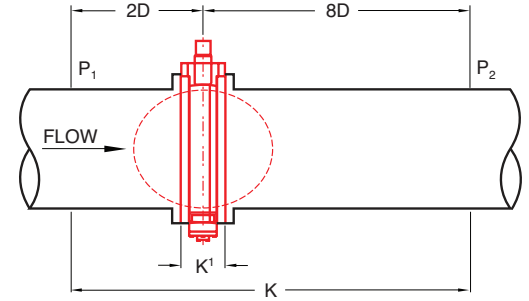

## FLOW COEFFICIENTS BASED ON "K"

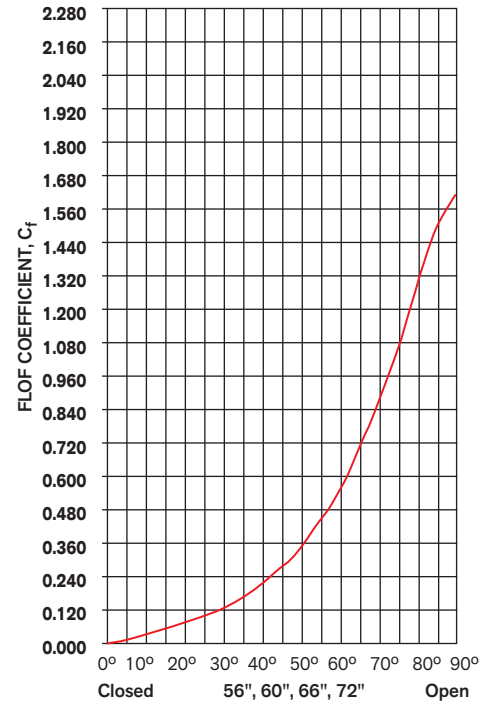
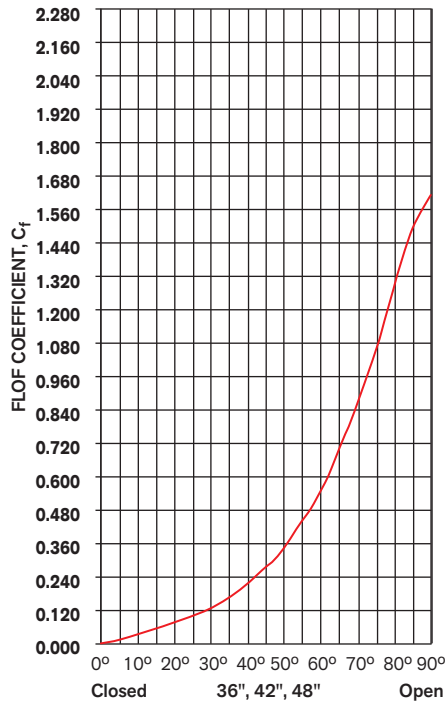
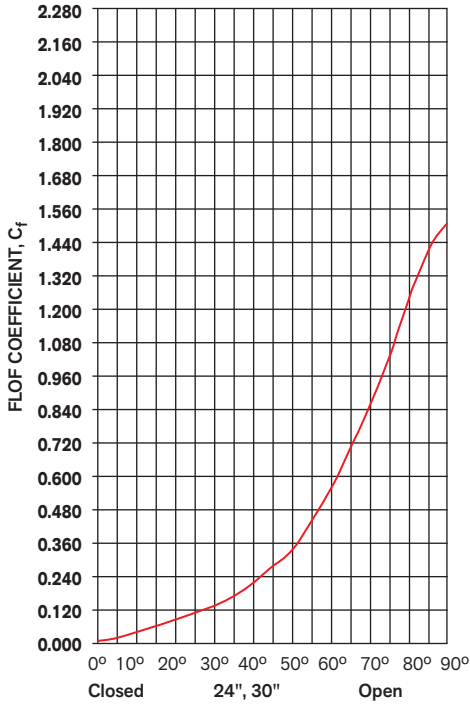

## FLOW COEFFICIENTS BASED ON "K' "

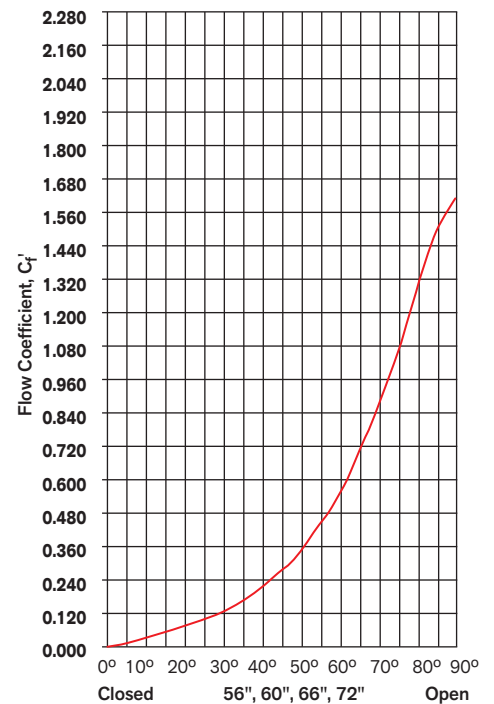
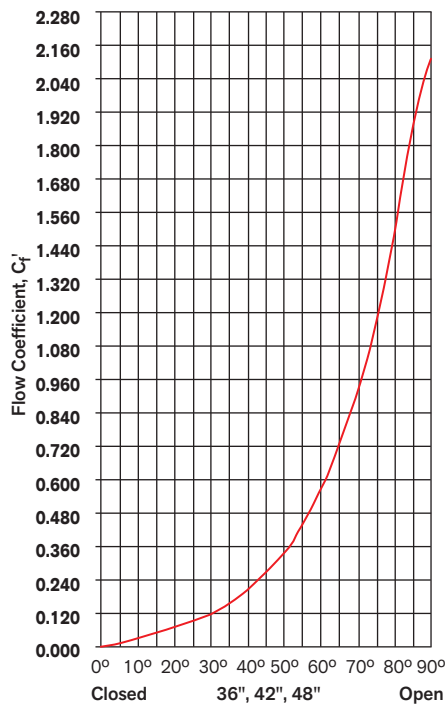
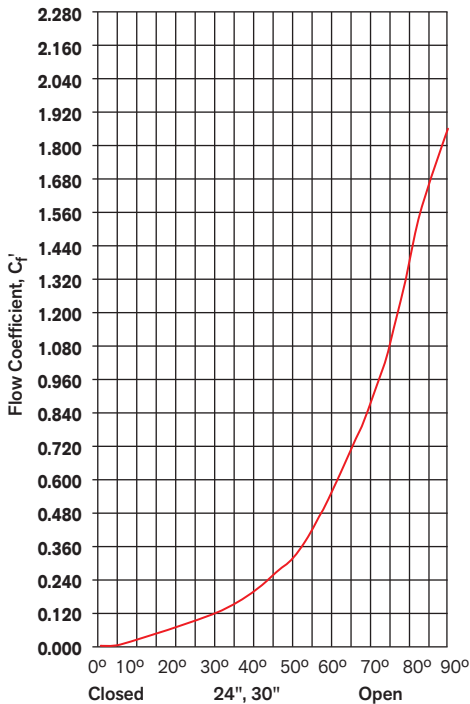

# Valve End Types and Dimensions: Flanged End

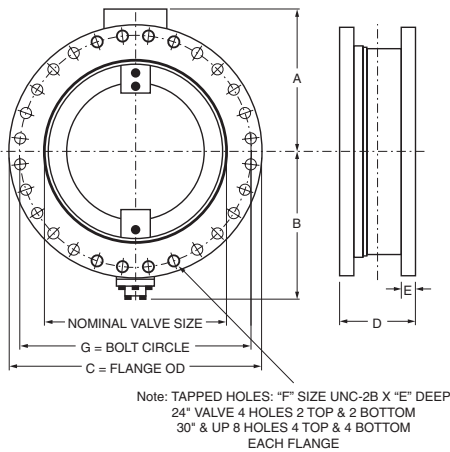

**Notes:**

- Dimensions shown in inches.
- Size = Nominal valve size.
- For bolts smaller than 1 ¼ inches in diameter, bolt holes will be ⅛ inches larger than diameter of bolts. For bolts 1 ¼ inches in diameter and larger, bolt holes will be ¼ inches larger than diameter of bolts. Dimensions and drilling of end flanges conform to ANSI B16.1 Standard for cast iron flanges.
- Allow 3 ½ inches for thrust bearing removal.
- F = Number and size of bolts. Class 125. Holes in trunnion area are tapped, see note.

SIZE	A	B	C	D	E	F	G
24	18 <sup>5</sup> / <sub>8</sub>	18 <sup>3</sup> / <sub>8</sub>	32	8	1 <sup>7</sup> / <sub>8</sub>	20-1 <sup>1</sup> / <sub>4</sub>	29 <sup>1</sup> / <sub>2</sub>
30	21 <sup>1</sup> / <sub>2</sub>	24 <sup>1</sup> / <sub>8</sub>	38 <sup>3</sup> / <sub>4</sub>	12	2 <sup>1</sup> / <sub>8</sub>	28-1 <sup>1</sup> / <sub>4</sub>	36
36	25 <sup>7</sup> / <sub>16</sub>	28	46	12	2 <sup>3</sup> / <sub>8</sub>	32-1 <sup>1</sup> / <sub>2</sub>	42 <sup>3</sup> / <sub>4</sub>
42	29 <sup>7</sup> / <sub>8</sub>	32 <sup>1</sup> / <sub>16</sub>	53	12	2 <sup>5</sup> / <sub>8</sub>	36-1 <sup>1</sup> / <sub>2</sub>	49 <sup>1</sup> / <sub>2</sub>
48	34 <sup>1</sup> / <sub>16</sub>	36 <sup>7</sup> / <sub>8</sub>	59 <sup>1</sup> / <sub>2</sub>	15	2 <sup>3</sup> / <sub>4</sub>	44-1 <sup>1</sup> / <sub>2</sub>	56
54	37 <sup>1</sup> / <sub>2</sub>	40 <sup>1</sup> / <sub>16</sub>	66 <sup>1</sup> / <sub>4</sub>	15	3	44-1 <sup>3</sup> / <sub>4</sub>	62 <sup>3</sup> / <sub>4</sub>
60	41 <sup>3</sup> / <sub>4</sub>	45 <sup>9</sup> / <sub>16</sub>	73	15	3 <sup>1</sup> / <sub>8</sub>	52-1 <sup>3</sup> / <sub>4</sub>	69 <sup>1</sup> / <sub>4</sub>
66	46 <sup>1</sup> / <sub>16</sub>	49 <sup>1</sup> / <sub>2</sub>	80	18	3 <sup>3</sup> / <sub>8</sub>	52-1 <sup>3</sup> / <sub>4</sub>	76
72	50	53 <sup>7</sup> / <sub>8</sub>	86 <sup>1</sup> / <sub>2</sub>	18	3 <sup>1</sup> / <sub>2</sub>	60-1 <sup>3</sup> / <sub>4</sub>	82 <sup>1</sup> / <sub>2</sub>

# Valve End Types and Dimensions: Mechanical Joint End

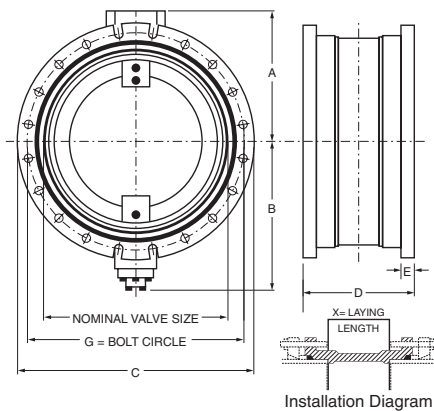

**Notes:**

- Dimensions shown in inches.
- Size = nominal valve size.
- Bolts, nuts, glands and gaskets not furnished unless otherwise specified in contract.
- Allow 3 1/2 inches for thrust bearing removal.
- F = Number and size of bolts.

SIZE	A	B	C	D	E	F	G	X
24	18 <sup>5</sup> / <sub>8</sub>	18 <sup>3</sup> / <sub>8</sub>	31 <sup>9</sup> / <sub>16</sub>	13 <sup>1</sup> / <sub>4</sub>	1 <sup>5</sup> / <sub>8</sub>	16- <sup>3</sup> / <sub>4</sub>	30	6 <sup>3</sup> / <sub>8</sub>
30	21 <sup>1</sup> / <sub>2</sub>	24 <sup>1</sup> / <sub>8</sub>	39	18	1 <sup>13</sup> / <sub>16</sub>	20-1	36 <sup>7</sup> / <sub>8</sub>	10
36	25 <sup>7</sup> / <sub>16</sub>	28	45 <sup>7</sup> / <sub>8</sub>	22	2	24-1	43 <sup>3</sup> / <sub>4</sub>	14
42	29 <sup>7</sup> / <sub>8</sub>	32 <sup>3</sup> / <sub>4</sub>	53	22	2	28-1 <sup>1</sup> / <sub>4</sub>	50 <sup>5</sup> / <sub>8</sub>	14
48	34 <sup>1</sup> / <sub>16</sub>	36 <sup>7</sup> / <sub>8</sub>	59 <sup>7</sup> / <sub>8</sub>	24	2	32-1 <sup>1</sup> / <sub>4</sub>	57 <sup>1</sup> / <sub>2</sub>	16

# Suggested Specifications: Butterfly Valves 24" and larger Cast Construction

## General

All butterfly valves shall be of the tight closing, rubber seated type and fully comply with the latest revision of AWWA Standard C504/C516 and NSF61, where applicable. Valves shall be bubble-tight at rated pressures in either direction, and shall be satisfactory for applications involving throttling service and for applications requiring valve actuation after long periods of inactivity. Valve discs shall rotate 90° from the full open position to the tight shut position. Regardless of valve size, angular misposition of disc can be up to 1° off center without leakage.

The manufacturer shall have manufactured tight closing, rubber seated butterfly valves for a period of at least ten years. All valves from 24" through 144" shall be the Triton XR-70 as manufactured by the Henry Pratt Company or an approved equal.

## Valve Body

All valve bodies shall be cast iron ASTM A126, Class B, narrow body design. Flange drilling shall be in accordance with ANSI B16.1 standard for cast iron flanges. Body thickness shall be in strict accordance with AWWA C504 where applicable.

## Valve Disc

All valve discs shall be constructed of ductile iron ASTM A536 with a stainless steel seating edge. The disc shall not have any hollow chambers that can entrap water. All surfaces shall be visually inspected and measurable to assure all structural members are at full disc strength. Disc and shaft connection shall be made with stainless steel pins.

### Typical Applications for Triton XR-70

Thousands of Triton XR-70 butterfly valves have been installed in plants and industrial facilities around the world. Some typical applications include the following:

- Water treatment
- Wastewater treatment
- Cooling water systems
- Circulating water systems
- Nuclear, fossil fuel and cogeneration power plants
- Pumping stations
- Reservoirs
- Pipelines

## Valve Shaft

All shafts shall be turned, ground, polished and constructed of ASTM A-276 Type 304 or Type 316 stainless steel. Shafts shall be two-piece, stub type and keyed for actuator connection. Shaft diameters shall meet minimum requirements established by the latest revision of AWWA Standard C504 for their class, where applicable.

## Valve Seat

All seats shall be constructed of synthetic rubber compound such as Buna N or EPDM and suitable for bidirectional shutoff at rated pressure. Seats shall be retained in the valve body by mechanical means without retaining rings, segments, screws or hardware of any kind in the flow stream. Seats shall be a full 360° without interruption and have a plurality of grooves mating with a spherical disc edge seating surface. Valve seats shall be field adjustable around the full 360° circumference and replaceable without dismantling the actuator, disc or shaft and without removing the valve from the line.

## Valve Bearings

All butterfly valves shall be fitted with sleeve-type bearings. Bearings shall be corrosion resistant and self-lubricating. Bearing load shall not exceed  $\frac{1}{5}$  of the compressible strength of the bearing or shaft material.

## Valve Actuator

Valve actuators shall conform to AWWA Standard C504 and shall be designed to hold the valve in any intermediate position between full open and fully closed without creeping or fluttering.

## Painting

All surfaces of the valve shall be clean, dry and free from grease before applying paint or coating. The valve interior and exterior surfaces, except for the seating surfaces, shall be provided with the manufacturer's standard coating unless otherwise specified by contract.

## Testing

Hydrostatic and leakage tests shall be conducted in strict accordance with AWWA Standard C504.

## Proof of Design

The manufacturer furnishing the valves under the specification shall be prepared to show proof that the valves provided meet the design requirements of AWWA Standard C504.

# Actuation

## Traveling Nut Type Manual Actuator

The Pratt MDT manual compound lever-traveling nut type actuator is the ideal manual actuation option for the Triton XR-70 butterfly valve. The MDT provides characterized closure, minimizing the possibility of line shock by slowing down the valve travel as the valve disc approaches the closed position. The high input torque capacity (450 foot pound maximum and a 200 pound pull on the handwheel or chainwheel) provides inherent protection from actuator misuse.

The Pratt MDT actuator is self locking without a unidirectional sustained force from the valve. It can be relied upon to maintain exact valve position under conditions of fluctuating, turbulent and intermittent flow.

Completely in conformity to the latest revision of AWWA Standard C504, the Pratt Triton valve, coupled with the MDT actuator, offers single source responsibility and reliability for both actuator and valve. To ensure that we can meet the delivery requirements of our valued customers, Pratt maintains an inventory of selected valves equipped with MDT actuators. Consult factory for availability.

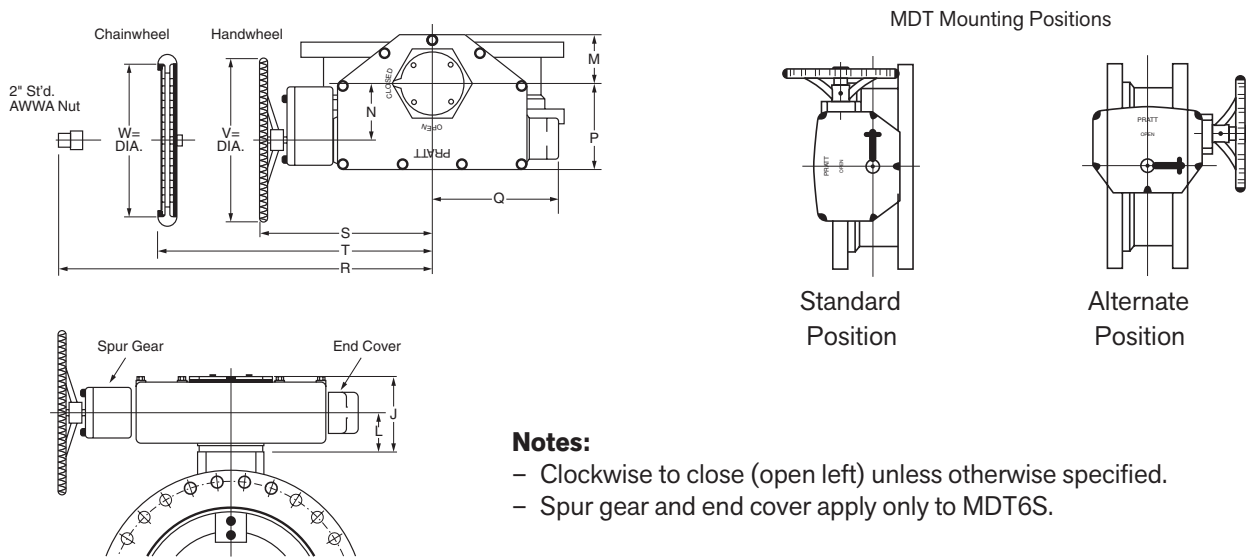

**Notes:**

- Clockwise to close (open left) unless otherwise specified.
- Spur gear and end cover apply only to MDT6S.

MDT Size	Dimensions										
	J	L	M	N	P	Q	R	S	T	V	W
MDT-3	7 <sup>3</sup> / <sub>4</sub>	4 <sup>1</sup> / <sub>16</sub>	3 <sup>1</sup> / <sub>4</sub>	3 <sup>5</sup> / <sub>22</sub>	5 <sup>5</sup> / <sub>8</sub>	5 <sup>3</sup> / <sub>8</sub>	9 <sup>1</sup> / <sub>4</sub>	10 <sup>1</sup> / <sub>2</sub>	10	12	9 <sup>1</sup> / <sub>8</sub>
MDT-4	8	4 <sup>1</sup> / <sub>2</sub>	3 <sup>3</sup> / <sub>8</sub>	4	7 <sup>5</sup> / <sub>16</sub>	6 <sup>3</sup> / <sub>4</sub>	10 <sup>1</sup> / <sub>2</sub>	11 <sup>1</sup> / <sub>2</sub>	11	12	9 <sup>1</sup> / <sub>8</sub>
MDT-5	10	5 <sup>5</sup> / <sub>8</sub>	4 <sup>1</sup> / <sub>2</sub>	5 <sup>1</sup> / <sub>2</sub>	8 <sup>3</sup> / <sub>4</sub>	10 <sup>1</sup> / <sub>2</sub>	17	17 <sup>1</sup> / <sub>8</sub>	17 <sup>7</sup> / <sub>8</sub>	18	16 <sup>7</sup> / <sub>16</sub>
MDT-5S	10 <sup>3</sup> / <sub>4</sub>	6 <sup>1</sup> / <sub>8</sub>	5 <sup>5</sup> / <sub>8</sub>	7	10 <sup>5</sup> / <sub>8</sub>	15 <sup>5</sup> / <sub>16</sub>	19 <sup>11</sup> / <sub>16</sub>	20	20 <sup>3</sup> / <sub>4</sub>	24	22 <sup>1</sup> / <sub>4</sub>
MDT-6S	12 <sup>7</sup> / <sub>8</sub>	7 <sup>5</sup> / <sub>8</sub>	7	8 <sup>1</sup> / <sub>4</sub>	12 <sup>5</sup> / <sub>8</sub>	18 <sup>5</sup> / <sub>8</sub>	26 <sup>1</sup> / <sub>2</sub>	26 <sup>3</sup> / <sub>4</sub>	25 <sup>7</sup> / <sub>8</sub>	24	22 <sup>1</sup> / <sub>4</sub>

\* The Triton XR-70 can be equipped with a wide range of cylinder actuators and electric motor actuators to meet your special operating requirements. Please consult our factory for additional information.

# Notes

# PRATT PRODUCT GUIDE

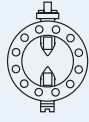

**Model  
2FI**

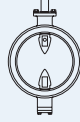

**Monoflange  
MKII**

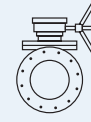

**Plug  
Valve**

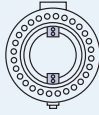

**Triton®  
XR70**

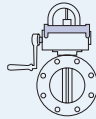

**Indicating Butterfly Valve  
UL & FM approved**

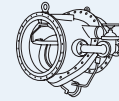

**Tilting Disc  
Check Valve**

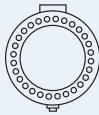

**Triton®  
XL**



**N-Stamp Nuclear  
Butterfly Valve**

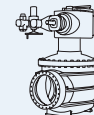

**Cone  
Valve**

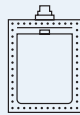

**Rectangular**



**PIVA Post Indicating Valve Assembly  
UL & FM approved**

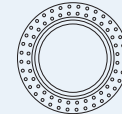

**Sleeve  
Valve**

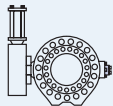

**Rubber Seated  
Ball Valve**

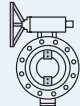

**Triton®  
HP250**

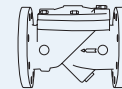

**Check  
Valve**



**Groundhog®  
Valve**



**Control  
Systems**

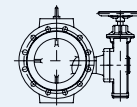

**Plunger Valve**

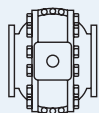

**Metal Seated  
Ball Valve**

**PRATT**

**Henry Pratt Company**

401 South Highland Avenue  
Aurora, Illinois 60506-5563 - US  
P: 630-844-4000 F: 630-844-4160  
www.henrypratt.com  
ISO 9001: 2000 Certified

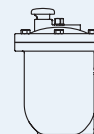

**Air Valve**