

SPECIFICATIONS

- CAST IRON BODY
- TWO PART EPOXY COATING
- BRONZE SEAT RINGS IN DISC AND BODY

Parts List

Item	Description	Required	Material
1	Flap Disc	1	Cast Iron A126
2	Disc Ring	1	Bronze B62
3	Seat Ring	1	Bronze B62
4	Valve Body	1	Cast Iron A126
5	Cotter Pin	2	Stainless Steel
6	Hinge Pin	1	Stainless Steel

Size	14	16	18	20	24	30
A	21.00	23.50	25.00	27.50	32.00	38.75
B	15.75	18.06	19.75	22.00	25.75	31.50
C	14.50	16.69	18.50	20.62	24.00	30.00
D	4.62	4.50	7.50	6.00	6.56	8.50
E	1.19	1.25	1.12	1.12	1.38	1.50
F	15.75	18.00	20.00	22.25	26.25	32.75
G	9.12	10.25	11.62	12.69	14.53	17.88
H	1.12	1.12	1.25	1.25	1.38	1.00
J	12	16	16	20	20	28
K	18.75	21.25	22.75	25.00	29.50	36.00

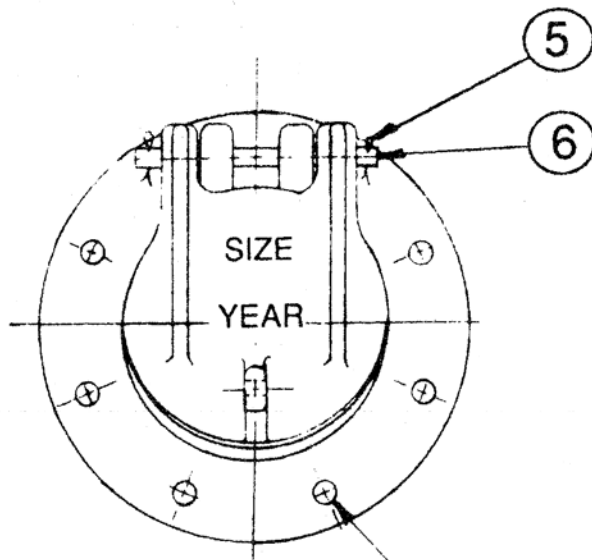

"H" Dia. of holes
 "J" no. of holes
 Equally spaced on
 "K" B.C. - Straddle

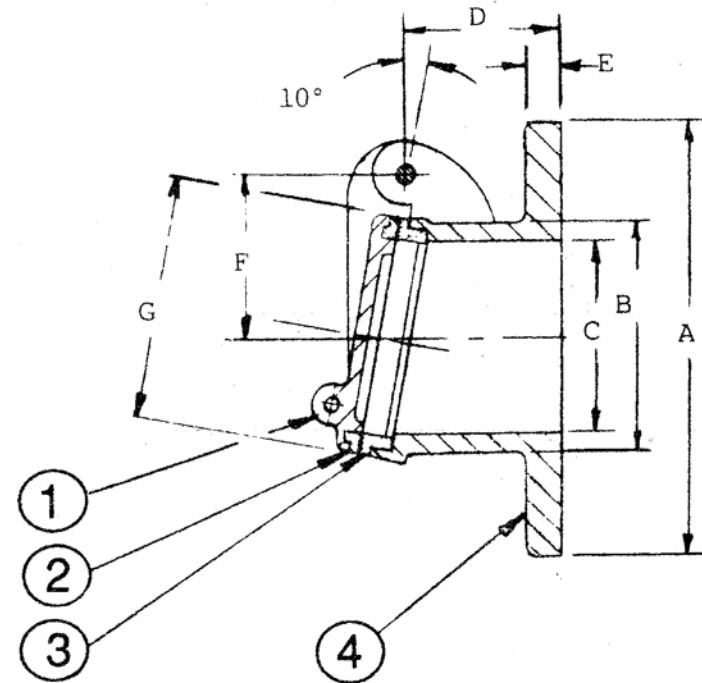

MATERIAL: As Noted

DATE:

FLAP VALVE/IBBM, 125 ANSI FLANGE

TROY VALVE

Troy, PA

NO.

A2540-6/E-3359