

SPECIFICATIONS

- CAST IRON BODY
- TWO PART EPOXY COATING
- BRONZE SEAT RINGS IN DISC AND BODY

Parts List

Item	Description	Required	Material
1	F/V Disc	1	Cast Iron A126 CL.B
2	Disc Ring	1	Bronze B62
3	Seat Ring	1	Bronze B62
4	F/V Body	1	Cast Iron A126 CL.B
5	Cotter Pin	2	Stainless Steel
6	Hinge Pin	1	Stainless Steel

Size	4	6	8	10	12
A	9.00	11.00	13.50	16.00	19.00
B	4.62	6.75	8.75	10.88	13.00
C	4.00	6.00	8.00	10.00	12.00
D	3.25	3.50	4.00	4.50	4.50
E	.62	.69	.75	.81	.88
F	3.44	4.50	5.62	6.88	7.91
G	5.00	7.00	9.25	11.50	13.50
H	.75	.88	.88	1.00	1.00
J	8	8	8	12	12
K	7.50	9.50	11.75	14.25	17.00

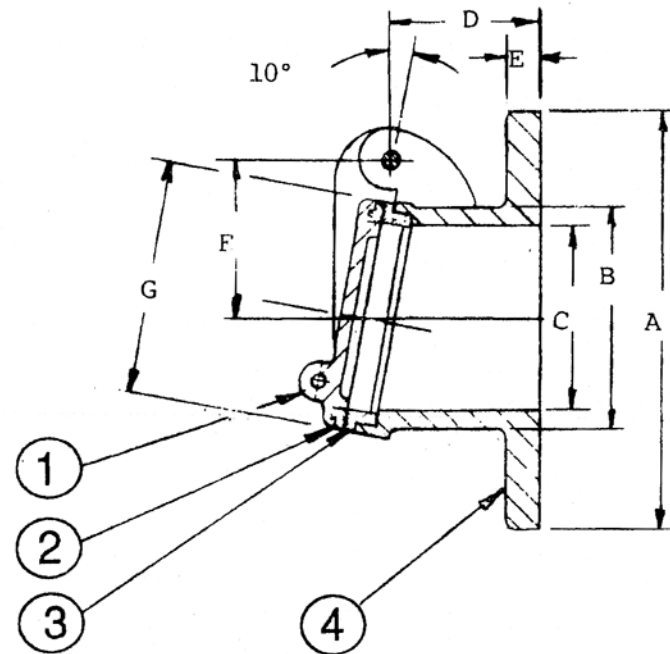
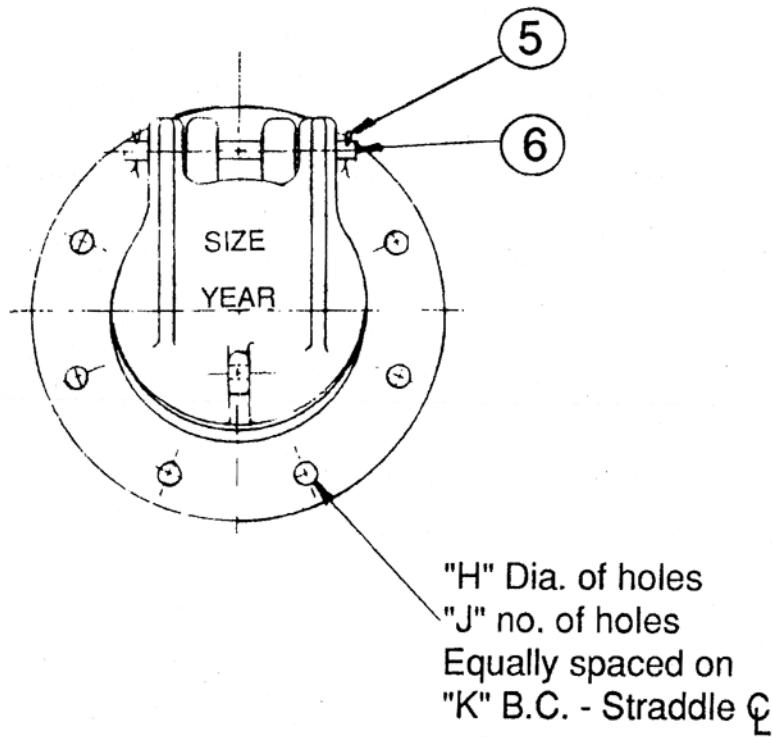

MATERIAL:	4"-12" FLAP VALVE / FLANGE
DATE:	
TROY VALVE Troy, PA	NO. E-3091